



Swathers

LINER





The world of CLAAS	04
Product overview	06
Technology for professionals	10
Rotor dome assembly	12
Tine arms	14
User-friendly features	16
Road transport	18
Top forage quality	20
Four-rotor swathers	26
LINER 4000 / 3600	28
Dual-rotor swathers (central swath laying)	32
LINER 3100	34
LINER 2900 / 2800	36
LINER 2700 / 2600	38
Dual-rotor swathers (side swath laying)	40
LINER 1900 / 1800 TWIN / 1700 TWIN	44
LINER 1700 / 1600 TWIN / 1600	48
LINER 800 TWIN / 700 TWIN	52
Single-rotor swathers	54
LINER 500 PROFIL	56
LINER 450 / 420	58
LINER 370 / 320	60
LINER 500 T / 450 T	62
CLAAS Service & Parts	64
Specifications	66

The world of CLAAS.

There are many reasons why we love what we do – because of the challenges it brings, because it demands all our expertise, and because it is constantly changing. Every day brings something new. No two fields are alike, and every customer is different. So our task is to find the optimum solution for every requirement, from the lush fields on East Frisian dikes to the drier soils of the Trentino region in Italy, or anywhere in the world.

Thankfully the LINER is equipped for every task. It meets every need in terms of working width, transport height, ground-contour following, time – and above all, feed quality.

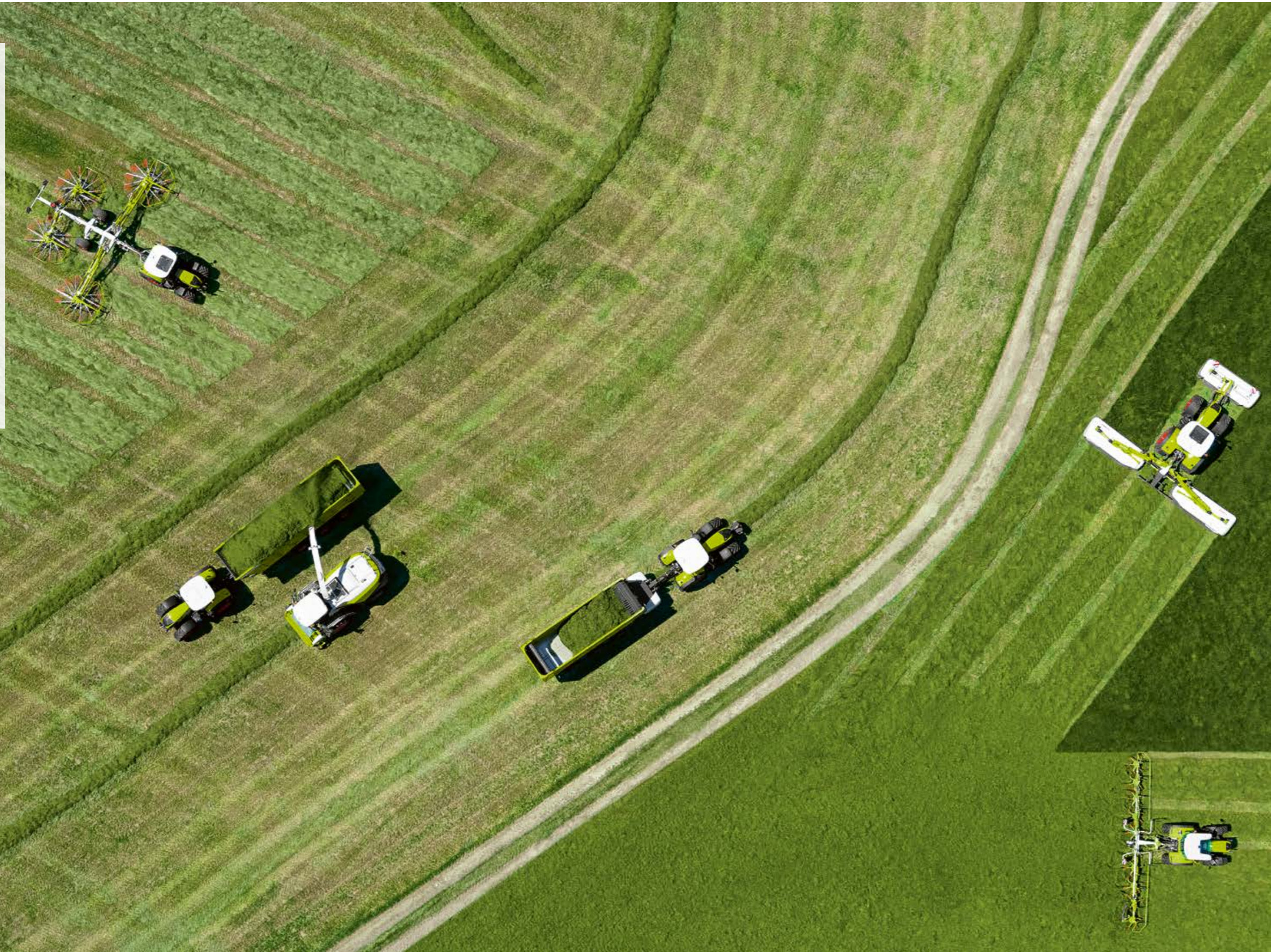

The ultimate in professional equipment – the four-rotor swather.

Versatile and multi-talented – the dual-rotor swather with central swath laying.

The classic – dual-rotor swather with side swath laying.

Compact single-rotor swather.

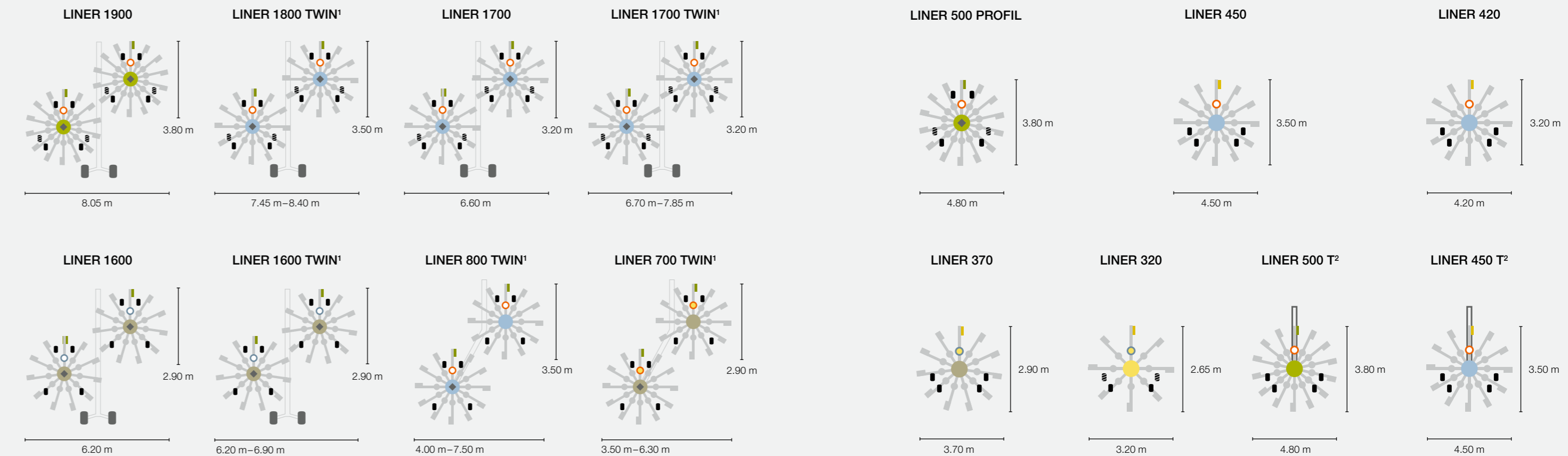
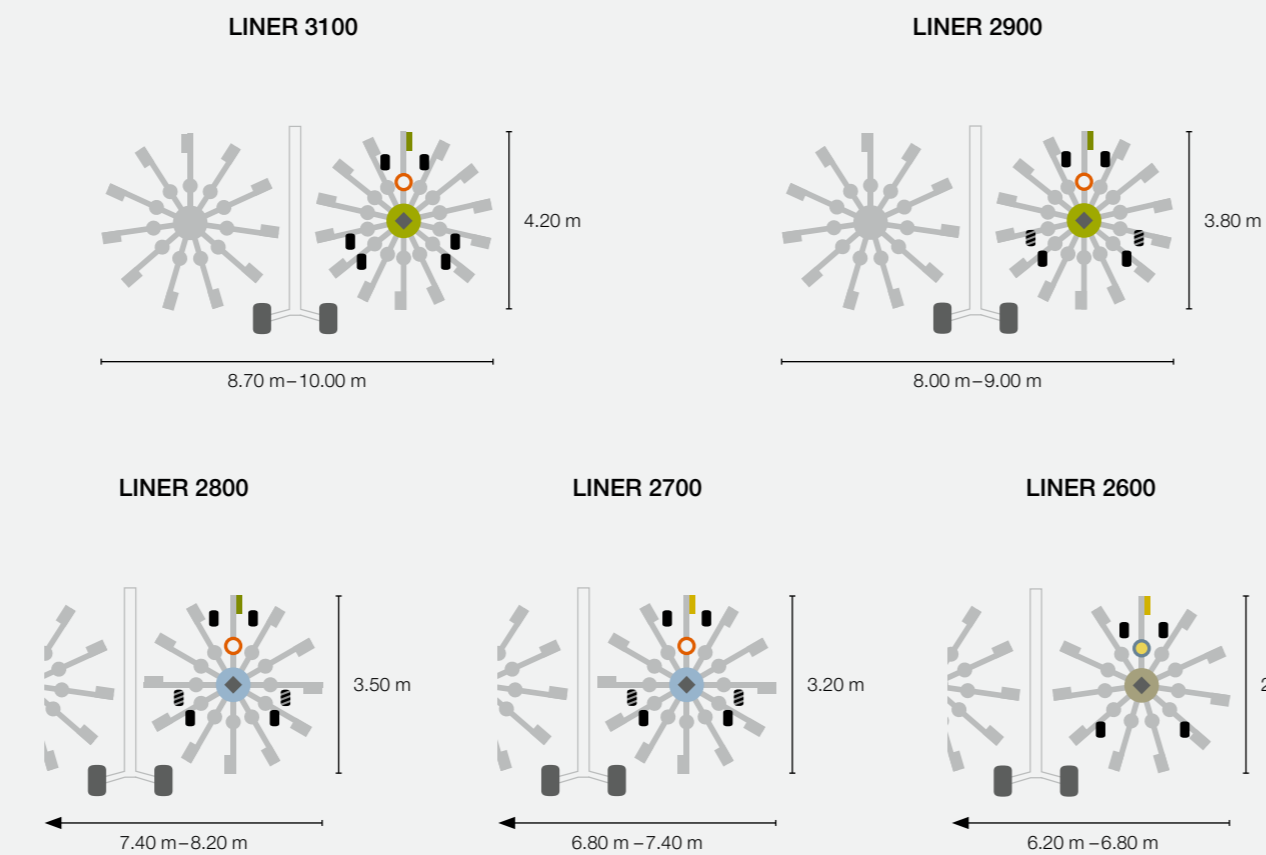
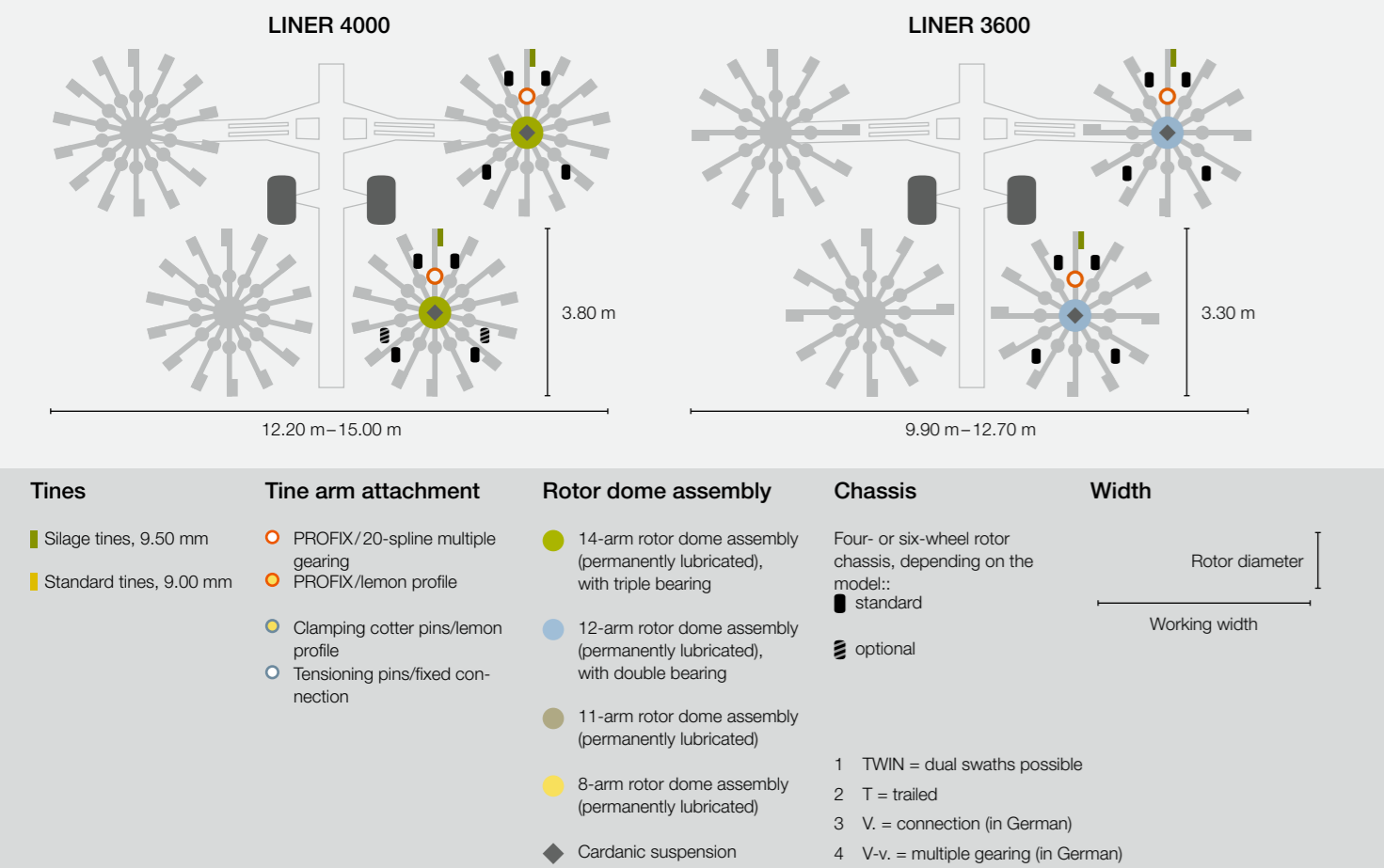

For the best results: swather know-how from CLAAS.

Sophisticated technology.

It goes without saying that our customers want only the best machines. CLAAS engineers work day in, day out to meet these expectations. Our swathers are the most innovative on the market, working choppers till they drop.

The forage harvesting centre of excellence.

The forage harvesting product development centre at the CLAAS plant in Bad Saulgau is one of the most modern and advanced facilities of its kind in the world. And since it is located right in the heart of Europe's largest continuous grassland region, CLAAS employees have a very good understanding of what needs to be done.

The best for the future, built on the best of the past.

Our customers are looking for versatile solutions that match their specific needs. As farms keep growing and changing, we keep pace by continuously developing our products. We retain the best of our existing technology, and keep improving everything else.

Team player in the harvest chain.

Conditions keep changing – as do people and harvesting processes. Continuous change places complex demands on machinery and equipment, which we meet with a powerful team of forage harvesting machines. One of our 20 LINER models will make an ideal member of your team.



CLAAS Saulgau GmbH is the company's forage harvesting centre of excellence, with one of the most modern product development facilities anywhere in the world today.

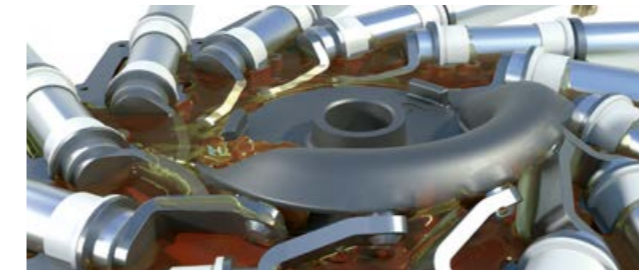

Cam track in oil bath: life-long maintenance-free reliability.



In 1998 CLAAS introduced the world's first four-rotor swather to keep the JAGUAR supplied with enough crop, and now has two top-performing models in the professional equipment segment.



Cardanic rotor suspension ensures that the rotors follow the ground contours independently of the tractor.



On-grip tines: the original robust and reliable performer, in all operating conditions.



The patented PROFIX tine arm bracket with multiple gearing: easy and convenient tine arm fitting and removal.



The unique chassis design of the CLAAS side swather allows lift heights of up to 70 cm.



In the event of a collision, the tine arms snap off at a set bending point, preventing any serious damage.



Tandem axle, for optimum tine position even at higher driving speeds.

For more efficient swathing, we have raked up a heap of really clever ideas.

Technology for professionals.

Luckily for us, when it comes to technology, you expect the best. This is what drives us to keep improving, and to keep coming up with new ideas. Great technology is all about meticulous attention to detail – it's the only way to ensure that the whole system runs smoothly. So we have focused all our know-how on paring our LINER technology back to the key priority: the consistent delivery of peak performance.

A smooth-running mechanism.

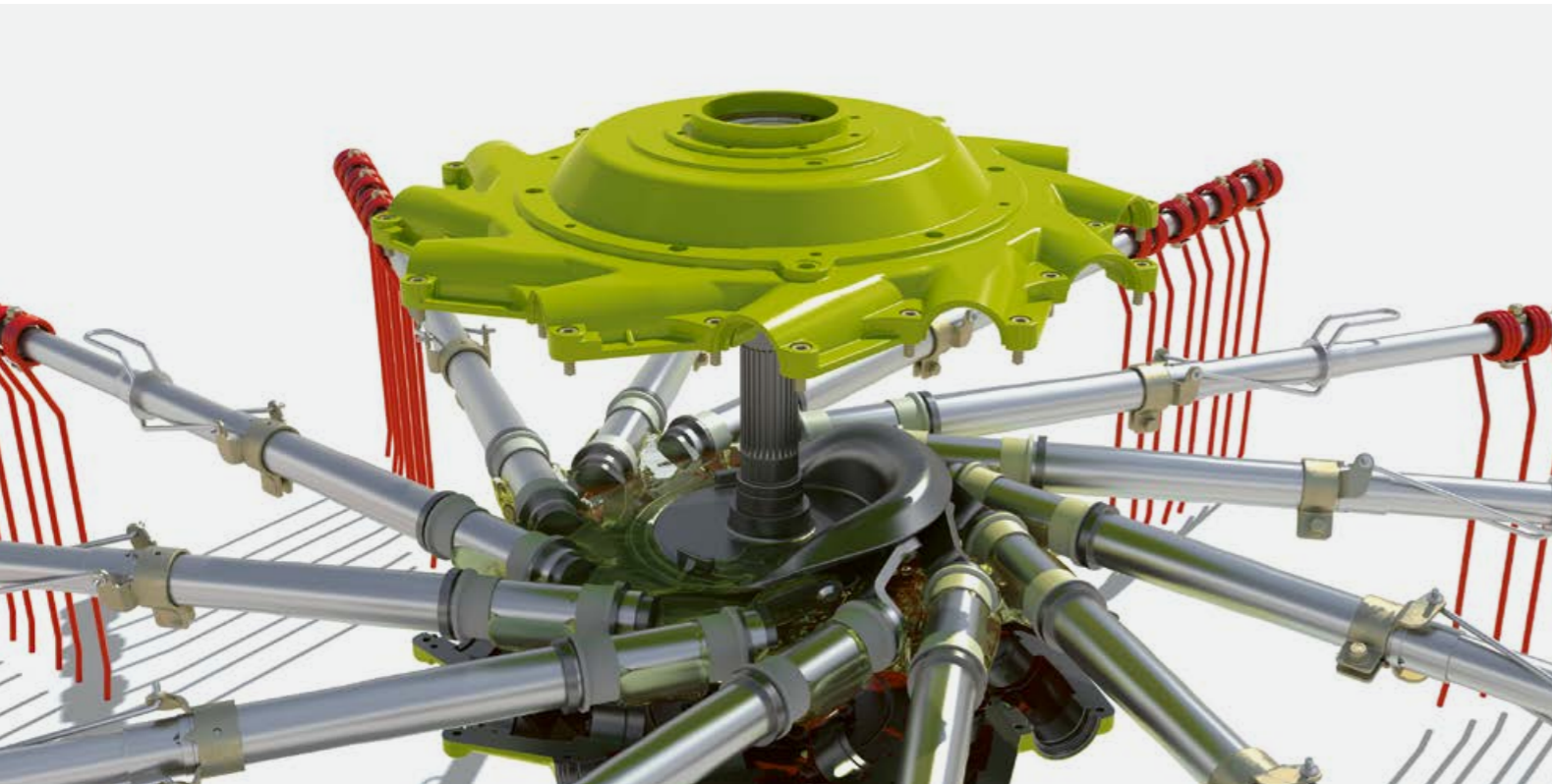

Continuously lubricated rotor dome assembly for professional operators.

The swathing transmission is located in a solid cast housing (rotor dome assembly), which is filled with oil and hermetically sealed. This means the core component of the LINER is protected from soiling, and is therefore maintenance-free. The cam rollers and all moving parts run smoothly in an oil bath, with virtually no friction. This provides optimum lubrication for maximum service life.

- Continuously lubricated, maintenance-free rotor dome assembly in all models
- Intelligent drive concept with individual rotor overload protection
- Robust and durable cam track, made of spheroidal graphite cast iron



The CLAAS long-running cam track.

High performance under all conditions – its spheroidal graphite iron construction gives the cam track the strength required to withstand any load. The large diameter and the gentle rise of the cam track minimise the thrust forces from the turning momentum. As a result, the tine arms operate smoothly, giving a clean raking action without material fatigue, even during periods of prolonged use.

Built to last.

The LINER's operating reliability and stamina make it an ideal part of the core forage harvesting team. To ensure clean swathing results when they matter most, all machine parts are designed to meet the most rigorous requirements.

The cam track arms have a triple-bearing system in the 14-tine arm rotor dome assembly, and a dual-bearing arrangement in the 12-tine arm version. The plain bearings are generously dimensioned and wear-resistant. This reduces wear on the cam rollers, protecting them against both horizontal and vertical loadings.



Compact: robust 11- or 8-arm rotor dome assembly.

Some of the small LINER models are fitted with a smaller rotor dome assembly. But here again the steel cam rollers are continuously lubricated in an oil bath, with the robust cast housing hermetically sealed and maintenance-free. The tine arms are secured to the cam track arms either by means of clamping cotter pins, or via a positive connection with a lemon profile.

Drive design concept.

LINER swathers feature a highly reliable, entirely external drive train, ensuring ease of access. The main driving force is transferred to the rotors via an auxiliary gearbox with intelligent gear ratios. That means you are always working at optimum revolutions, which reduces fuel consumption and also protects the crop material. An integrated freewheel mechanism is fitted as standard, to protect the rotors against overload.

Low maintenance.

The LINER is an incredibly low-maintenance machine, with a 250-hour lubrication interval for the universal joints of the drive shafts, and a 50-hour interval for the tractor drive shaft.

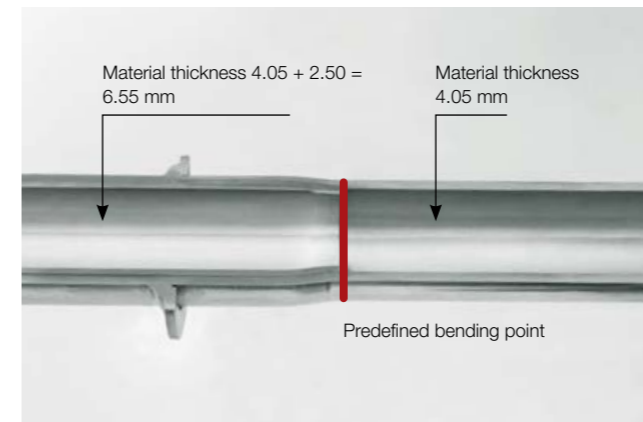
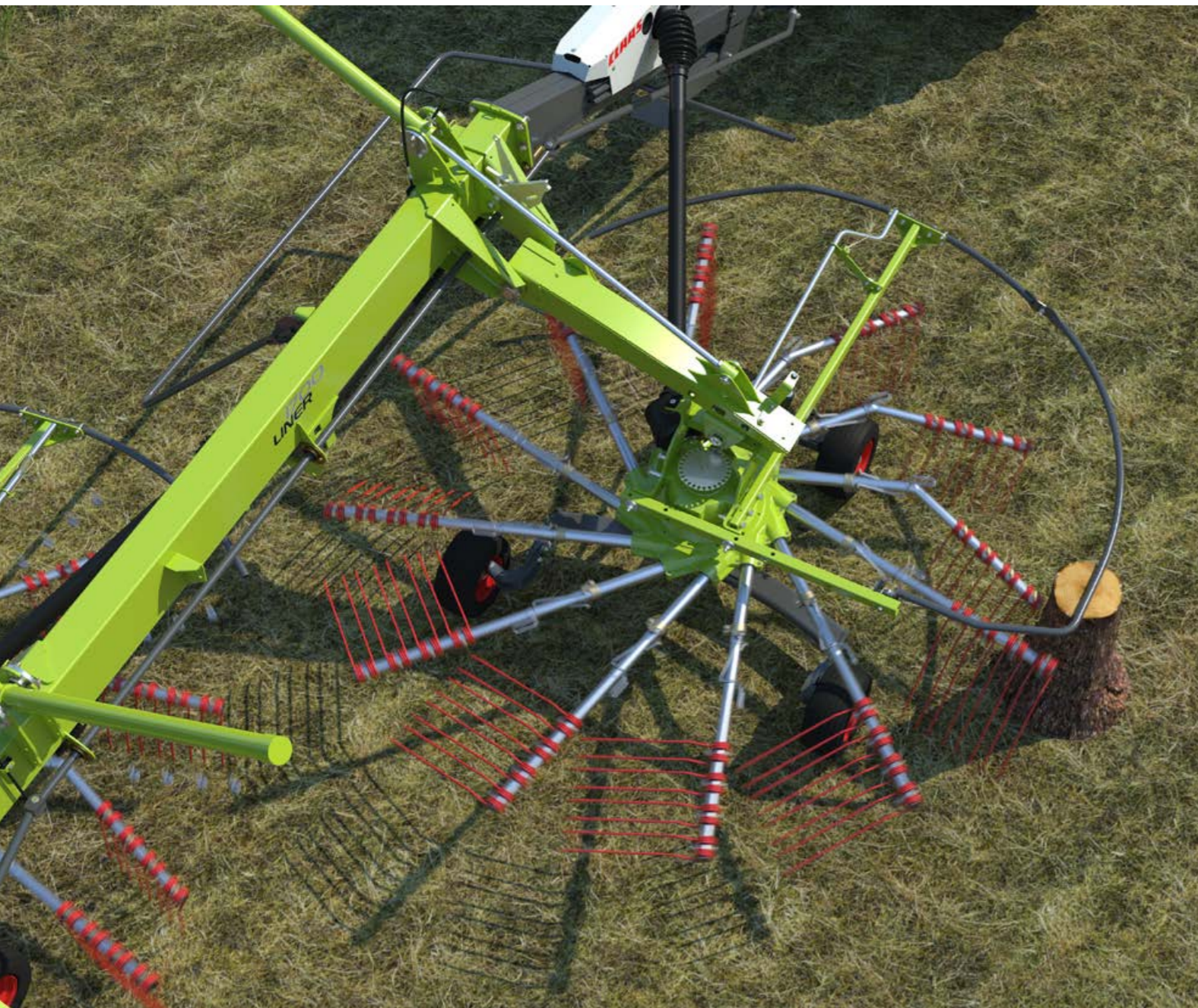

Patented PROFIX system.

In the event of a collision with an extraneous object, the tine arms deflect at a predefined bending point and are then easily replaced, thanks to the patented PROFIX bracket mounting. The bending points are located outside the rotor dome assembly, which therefore remains undamaged. All PROFIX tine arm bracket components can be replaced in a matter of moments, at minimum expense.

The 20-spline multiple gearing attachment keeps the tine arms firmly attached, with no play, and therefore no wear. The seating position is clearly indicated with marker arrows.

Predefined bending points in all models.

In the smaller 11-arm rotor dome assembly, the tine arms are attached with PROFIX, clamping splints or tensioning cotters, according to the model. In the 8-arm rotor dome assembly, clamping splints are used. In both rotor dome assemblies, in the event of a collision the tine arms deflect at a predefined bending point, and can be immediately replaced.

Strong arms for every rotor.

The generous tube diameter and wall material thickness make the tine arms extremely strong. The tine arm length varies according to the model, so the same type of rotor dome assembly can have different rotor diameters (see table).

Rotor diameter			
14-arm rotor dome assembly	12-arm rotor dome assembly	11-arm rotor dome assembly	8-arm rotor dome assembly
4.20 m or 3.80 m	3.50 m, 3.30 m or 3.20 m	2.90 m	2.65 m

- Predefined bending points on all tine arms
- Faster tine arm replacement in the event of a collision, with the PROFIX attachment system
- Top-quality materials for maximum strength



Lemon profile attachment and PROFIX tine arm bracket in the LINER 700.



Lemon profile attachment and clamping splint in the LINER 370 and 320.

Work first, and then play –
with the LINER you can do both at once.



- Clean swath, thanks to step sequencing and maximum lift heights
- Narrow turning circle and safe road transport
- Easy adjustment of working height and rake width

Adjustable hydraulic step sequencing.

On folding up into the transport position or when lifting at the headland, the rotors are first raised parallel to the ground, and only then turn inwards. This means the swath is not spoiled by rotating tines. During lifting, the front section of the rotor is raised first and during lowering, the rear chassis wheels contact the ground before the front wheels. As a result, the tines do not dig into the soil, and the harvested crop stays clean.



Maximum lift heights for clean swaths even at the headland.

Unmatched lifting heights.

The maximum lifting height at the headland allows you to drive over even the largest swaths with ease. So you can turn quickly, with no effect on the clean swath.



Dynamic handling, even in a tight space.

Maximum manoeuvrability.

The maximum steering lock is marked on the drawbar. This is a great advantage in the field, and essential when negotiating narrow entrances, for example.

Flexible rake height and width.

Both working height and rake width are easily adjustable on all models. The larger models have a scale on the telescopic arms for optimum rake width adjustment. The rake height can be read off the central shaft of the rotor chassis at any time, and adjusted as required.



Keeping it flexible, with the rake height adjustment scale.



- Road transport height of less than 4.00 m
- Low centre of gravity means excellent road stability, at speeds of up to 40 km/h
- Storage racks and holders for all cables and the drive shaft keep the cab tidy



With some models, the tine arms have to be removed for road transport – but they can be stowed away in no time at all.



All tidied away: the right solution for every model.

Safe, compact and fast transport on the road.

Almost all models fold down to a transport height of less than 4.00 m without having to remove the tine arms.

On two-rotor and four-rotor swathers, the rotors are folded upwards, and then hydraulically retracted, from the cab. They are then mechanically or hydraulically secured for transport. This is both convenient for the user and extremely safe: the LINER's low centre of gravity ensures excellent on-road stability, even at travel speeds of up to 40 km/h.

In models with larger rotor diameters, the tine arms can be quickly and easily removed, thanks to the PROFIX attachment system, and stowed in the tine arm holders provided. For even greater safety, most LINER models are equipped with lights and hazard signs as standard. Otherwise, these features are available as options.

Clean and tidy.

The reliable and easy-to-use stand provides a convenient stowage surface for the drive shaft. And depending on the model, there are also user-friendly holders for hydraulic hoses and cables. So the machine can be parked away tidily, out of harm's way.

Rotating hose holders avoid any strain on the connection with the tractor.

There is plenty of clearance around the drive, allowing a steering lock of up to 80°.

Optimum quality for the connoisseur – and satisfaction for all.

Top forage quality.

Harvesting windows are often very short because of the weather. CLAAS forage harvesting machines are therefore designed for reliable operation at maximum capacity – it's the only way to get the crop harvested at the right time. This is the key to producing top-quality feed, and also protects the soil and grass cover, so next season can be just as successful.





- The cardanic rotor suspension adapts effortlessly to uneven terrain
- Adjustable swathing rotor angle
- Sturdy, flexible tines ensure clean crop pick-up

Cardanic rotor suspension.

For three-dimensional ground contour following, the rotors move both lengthwise and crosswise to the direction of travel, independently of the position of the main frame.

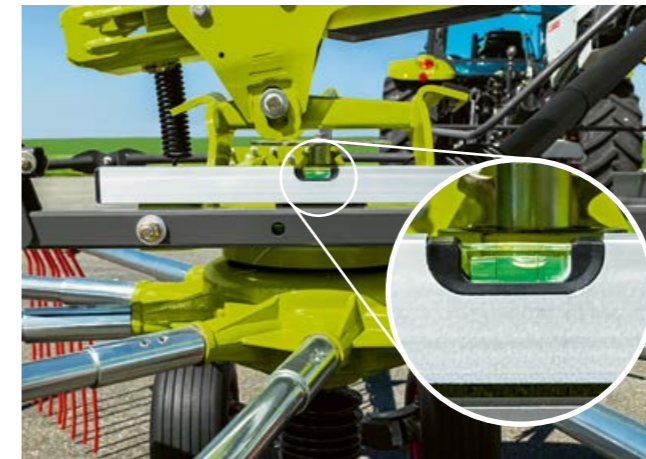

Rotor adjustment – simplicity itself.

The swathing rotors are set correctly when placed at the minimum angle of inclination towards the swath. To adjust this angle, simply select the appropriate insertion position on the main shaft of the rotor chassis. This is the only way to ensure complete pick-up of the crop material. The end result is a perfect swath, even at high travel speeds.



When the tine is right...

Not all tines are created equal. The material has to be right, and more particularly, the tine thickness. Both strength and flexibility are required for clean crop pick-up and transport without soiling.

CLAAS silage tines achieve this with a 9.50 mm tine thickness and 10° angle at the bottom of the tine. We continuously refine the product design to ensure that the tines grab reliably in all operating conditions. CLAAS engineers thrive on this kind of challenge. For them, it's not just about having good ideas, but turning them into the best possible solutions. It's also about vision, seeing further than the edge of the next rotor!

Which is precisely why CLAAS is not only an expert in crop flow and ground-contour following – we are at the leading edge of tine research.

Firmly grounded, even at high speeds.

Top forage quality

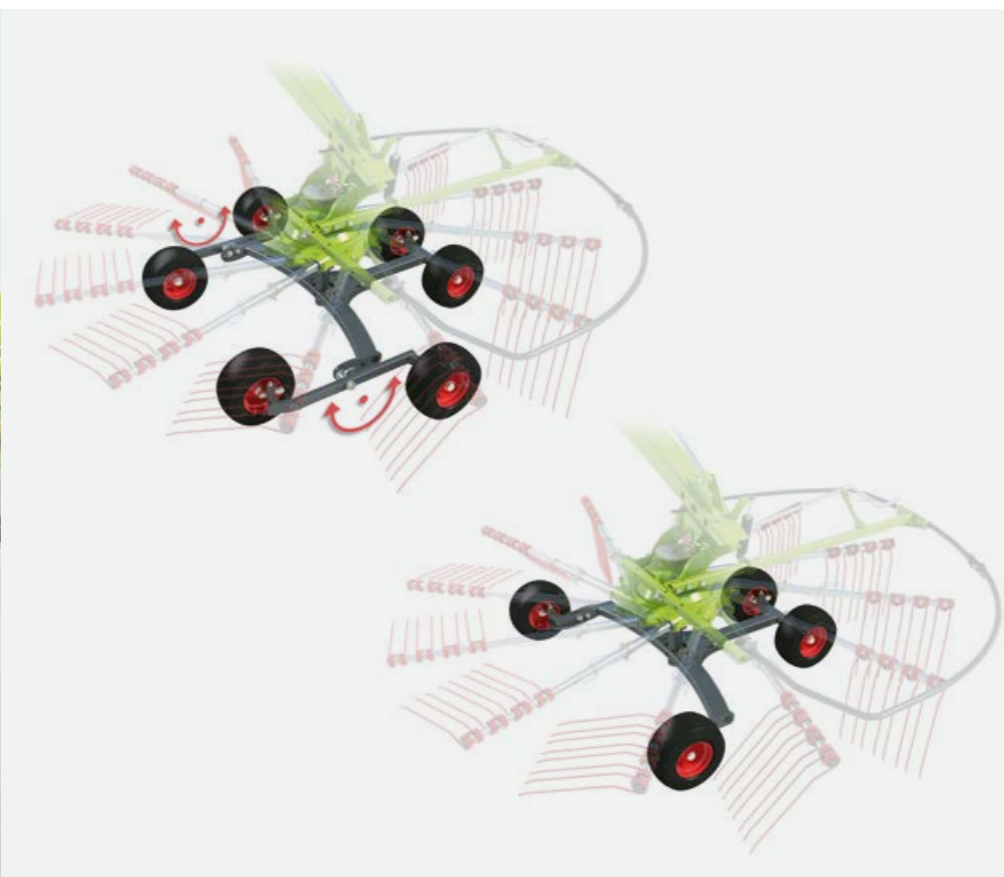

Ideal weight distribution.

The high-volume tyres on the main chassis give the LINER a wide track and a maximum contact area. This means that the weight is distributed optimally, and the soil is protected. The chassis provides the greatest possible stability on slopes, and on roads it enables high speeds of up to 50 km/h.

- Optimum ground-contour following protects both the soil and the crop
- Chassis stability on all types of terrain
- Optional guide wheel, with tool-free adjustment (depending on the model)

The chassis follows the ground contours.

The four-wheel or six-wheel chassis ensures optimum travel of the swather over the ground. The trailing-steered wheels on the front rotor and at the front of the rear rotor provide optimum soil protection. And the rigid wheels on the rear of the back rotor stabilise the LINER on hilly terrain.

The wheels are positioned close to the tine circle of rotation for clean harvesting results over the entire working width, on both flat and sloping ground.



Precisely adjusted rake height with additional guide wheel.

A guide wheel which can be adjusted without tools is optionally available for some single-rotor swathers. This helps to maintain the correct height, particularly in hilly terrain, and keeps the rotor moving smoothly and cleanly over the ground.

Four times optimum productivity –
as you'd expect from the ultimate professional.

Four-rotor swather.

With the four-rotor swathers, swathing bottlenecks are a thing of the past. The LINER four-rotor swathers have a level of power, intelligence and reliability that sets them apart.

LINER 4000	12.20–15.00 m
LINER 3600	9.90–12.70 m



Unbeatable teamwork –
18 metres in a single pass.



Peak production from combined forces, based on high working widths.

The key to a faster return on higher upfront investment costs is to have the right combination of machines working for you. Bigger working widths significantly reduce overlap between passes – which automatically boosts the productivity of your forage harvester or loading wagon.

18-to-12 mowing strategy with the DISCO 9200 C.

With the DISCO 9200 C AUTOSWATHER, you can lay a working width of 18.00 m on 12.00 m, using the machine's belt units. The crop is then formed into a single swath with the LINER 3600. The result is 50% more grass in the swath for the JAGUAR harvester following along behind.

Flexibility at the headland.

The benefits are self-evident:

- Adjustable time sequence for lifting and lowering of the front and rear rotor pairs
- Hydraulically adjustable, infinitely variable lift height at headlands to suit every type of forage crop
- Automatically folding swath guard for maximum ground clearance

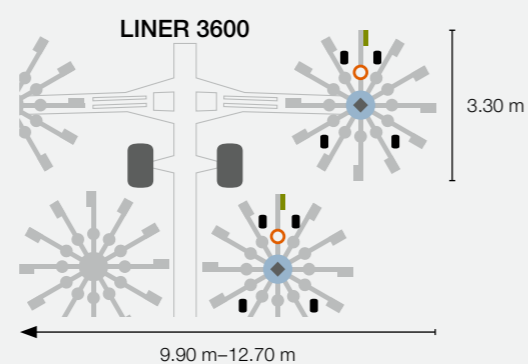
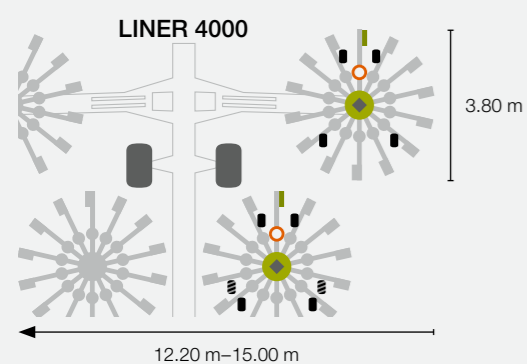

- Silage tines, 9.50 mm
 - PROFIX/ 20-spline multiple gearing
 - Four- or six-wheel rotor chassis, depending on the model:
 - standard
 - ▨ optional
 - 14-arm rotor dome assembly (permanently lubricated), with triple bearing
 - 12-arm rotor dome assembly (permanently lubricated), with double bearing
 - ◆ Cardanic suspension
- Rotor diameter
- Working width



Outstanding results – see for yourself.



It couldn't be gentler.

The four-wheel rotor chassis with steered front wheels and a laterally suspended front axle, or the six-wheel rotor chassis for the rear rotor pair which is optionally available with the LINER 4000 and features additional tandem axles and trailing-steered wheels, ensure optimal protection for soils.

- Optimal ground-contour following for a clean crop harvest, even at high working speeds
- Powerful spring packs cushion the rotors
- Suspended mounting of the rotor chassis front axle for precise rotor guidance
- Large 380/55-17, 500/50-20 or 620/40 R 22.5 road tyres for optimum ground protection and maximum stability during transportation

Available with hydraulic brakes, air brakes or unbraked, depending on specific national regulations.



Both four-rotor swathers are also available as comfort models, with electrohydraulic raking height adjustment.



Comfortable to operate.

The LINER 4000 and 3600 feature comfort hydraulics as standard. Both models can be operated via the OPERATOR, the COMMUNICATOR II, EASY on board, the S10 terminal or any other ISOBUS-capable terminal. Manual and electrohydraulic rake height adjustment are available. ISOBUS operation allows various functions to be assigned to the tractor's spool valves, providing additional support for the driver in the form of numerous automated processes.

- Can be conveniently folded in and out from the comfort of the cab
- Infinitely variable hydraulic adjustment of swath width
- A range of parameters can be set and stored to match a particular set of operating conditions (such as different rake heights)
- Overview of all the work performed and customer data in conjunction with the hectare counter
- Performance optimisation with steering systems
- Lower fuel consumption
- Utilisation of the full working width increases area output

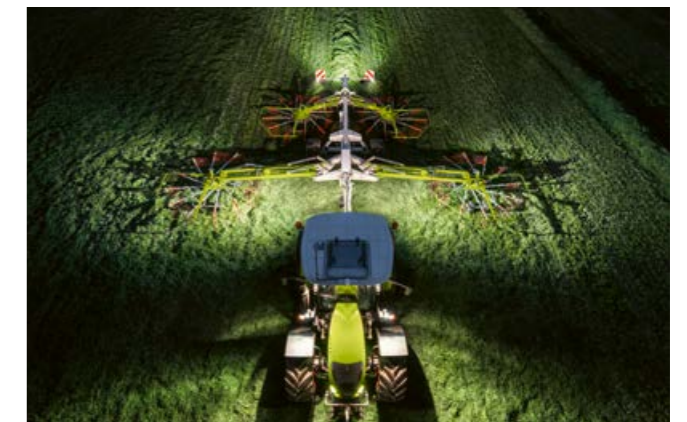

LEDs – so you're never left in the dark.

Even when you need to work well into the night, you can still keep your eye on the job, with five optional LED work lights (one for each rotor and one for the swath). The special light provides maximum contrast, yet without dazzle, ensuring optimal illumination around the swather. The work lights are activated automatically along with the tractor lights when darkness falls.

Swath width adjustable according to the conditions.

In the LINER 3600 the swath width can be adjusted mechanically with a lever, while the LINER 4000 has user-friendly hydraulic adjustment from the terminal, to suit different crop densities and all widely used pick-ups, from 1.20 to 2.60 m.

Less than 4.00 m without removing tine arms.

The hydraulically lowered transport chassis reduces the transport height of both models to less than 4.00 m, without having to remove the tine arms (with 22.5" tyres for the LINER 3600).

Best in class –
the power of two.



Dual-rotor swathers with central swath laying.

The reliable alternative to the four-rotor swather is the ideal choice when flexibility is called for in addition to a high work rate. Whether working with silage, hay or straw, the LINER dual-rotor swather with central swath laying and working widths of between 6.20 and 10.00 m is unmatched in its class.

LINER 3100	8.70 – 10.00 m
LINER 2900	8.00 – 9.00 m
LINER 2800	7.40 – 8.20 m
LINER 2700	6.80 – 7.40 m
LINER 2600	6.20 – 6.80 m

Your trusted specialist –
and not just in straw.



Power and efficiency with two rotors.

The LINER 3100 is a reliable performer in straw, and just about any other crop. The working width is infinitely variable and features a hydraulic adjustment system with a scale showing the current setting. When working with a straw crop, the LINER 3100 easily has the working width required to combine two swaths from a 7.50-m combine harvester cutterbar.

Large rotor to cope with even the thickest swaths.

Its generous rotor diameter and the 14 PROFIX tine arms, each with five double tines, ensure that nothing is left behind. And with a lift height of up to 90 cm, the LINER 3100 passes effortlessly over even the largest straw swaths. The lift height

can be adapted to any harvesting conditions via infinitely adjustable hydraulic headland stops. At headlands, the swath guard automatically folds upwards, giving maximum clearance.

User-friendly options through flexible control.

Electrohydraulic individual rotor lift function and hydraulic rake height adjustment can be conveniently operated via the CLAAS STANDARD TERMINAL with no need for ropes. Alternatively, the single-rotor lift can be operated without a terminal via a three-way valve.



Time-saving and safe on the road.

To get the transport height down to below 4.00 m, three tine arms can be removed from each rotor and secured in the appropriate holder right next to the rotor.



Ideal for tight curves: the steering system.

As the tractor turns, this action is passed to the large wheels fitted to the main chassis via the hitch, transfer lever and steering linkage.

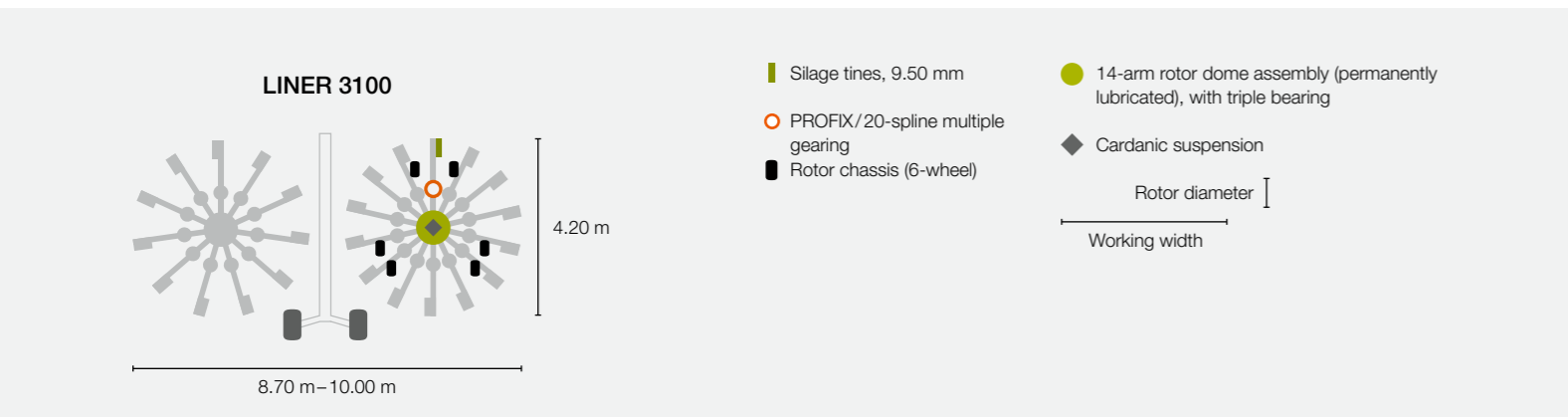

The time saver –
efficient, tidy, consistently successful.



LINER 2900.

The LINER 2900, with its 14 PROFIX tine arms, is the ultimate performer and true silage professional. So it's no surprise that contractors like to use it ahead of a forage harvester or loader wagon. And the box-shaped swaths are ideal for producing well-formed straw bales.



LINER 2800.

The LINER 2800 is a slightly smaller machine, more popular with farmers. Its 12 tine arms also deliver tidy and reliable raking results, but with a more compact swath with a maximum of 2.20 m.

Consistent, uniform swathing with the LINER.

The LINER 2900 and 2800 have a successful track record dating back many years. They consistently produce a perfectly formed swath that is cleanly picked up with the follow-up machines. The swath width can be hydraulically adjusted to suit the operating conditions via a double-acting spool valve.

Both models feature infinitely variable headland stops to accommodate a wide range of forage crops. The automatic hydraulically folding swath guard provides the maximum possible ground clearance.

Optimum ground-contour following.

Both models can be supplied on request with a six-wheel rotor chassis and additional tandem axles, and trailing-steered wheels.



Efficient control system.

On the LINER 2900 and 2800, the individual rotor lift and rake height can be adjusted using the CLAAS STANDARD TERMINAL with no need for ropes. Alternatively, the individual rotor lift function can be controlled via a three-way valve.

Convenient transport.

All models fold down to a transport height of less than 4.00 m, with hydraulic retraction of the rotors. And the automatic transport lock function makes the operation particularly convenient for the user.

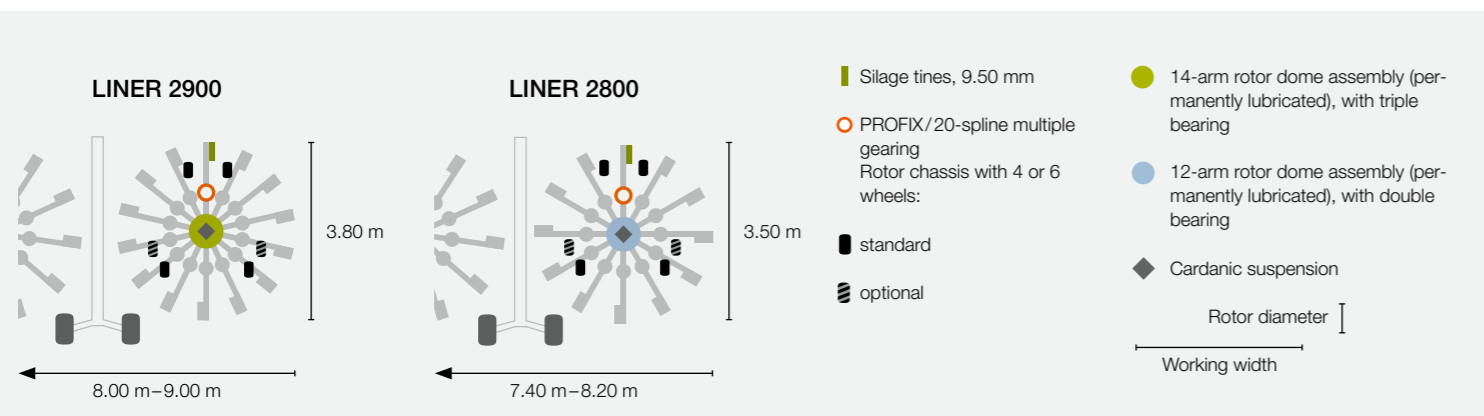



Stability.

The strong frame structure and large tyres provide maximum stability. In all models, the wheels of the frame are controlled with active steering. The benefits include flawless trailing and optimum adaptation to the tractor position.

Powerful and flexible.

The two small central swath models are also highly versatile performers. The swath width can be mechanically adjusted to suit the operating conditions.

The rotors are secured with a mechanical locking system for safe road transport.



LINER 2700.

Like its larger counterparts in the central swath segment, the LINER 2700 is fitted with the PROFIX tine arm attachment system. With a maximum swath width of 2.00 m, it is ideal for farms that organise their own baling or loading operations.



LINER 2600.

Unbeatable price-performance ratio. The LINER 2600 has everything a swather needs – including a maintenance-free, hermetically sealed rotor dome assembly, permanently filled with oil.

The LINER 2600, with a maximum swath width of 1.80 m, is particularly impressive in haymaking operations.

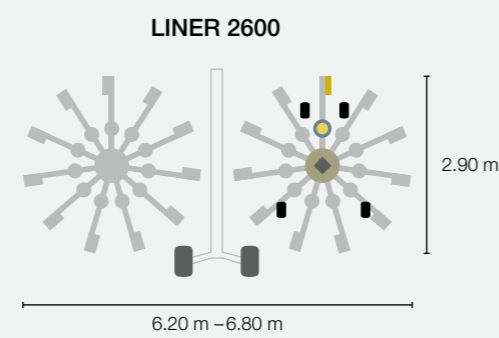
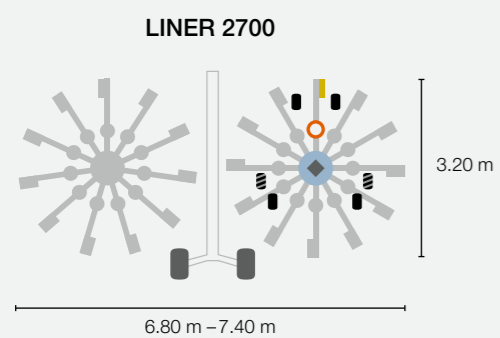

- Standard tines, 9.00 mm
- PROFIX/20-spline multiple gearing
- Clamping cotter pins/lemon profile
- Four- or six-wheel rotor chassis, depending on the model:
- standard
- optional
- 12-arm rotor dome assembly (permanently lubricated), with double bearing
- 11-arm rotor dome assembly (permanently lubricated)
- Cardanic suspension
- Rotor diameter
- Working width

The bigger the family –
the wider the range of skills and talents.

New arrivals in the side swathing range.

We've added a further three models to our product range. The dual-rotor swathers with side discharge and three-dimensional rotor frame guarantee meticulous swathing in all situations.

LINER 1900	8.05 m
LINER 1800 TWIN	7.45 m – 8.40 m
LINER 1700	6.60 m
LINER 1700 TWIN	6.70 m – 7.85 m
LINER 1600	6.20 m
LINER 1600 TWIN	6.20 m – 6.90 m

Worm swathers too (trailed machines with no extra chassis), with working widths between 3.50 and 7.50 m, offer both flexibility and outstanding productivity, even with low crop densities.

LINER 800 TWIN	4.00 m – 7.50 m
LINER 700 TWIN	3.50 m – 6.30 m



Sometimes the best way to lead is to follow – especially when it comes to ground contours.



For superior swathing: trailed cardanic suspension.

The innovative rotor suspension on a stable ball coupling mount allows the rotors to oscillate laterally and longitudinally independently of the main frame. The combination of maximum oscillation travel and outstanding stability provides optimum ground-contour following, even with deep ruts and bumps. As a result, the LINER rotary swathers deliver superior swathing results, all the time, in any conditions.

"Inferior feed equals poor quality livestock."

High-quality forage is the key to success. That means choosing the best time for harvesting, and then handling the crop correctly. This starts with the ground-contour following, because the harvesting machines have to produce a clean crop if our farmers are to achieve their targets:

- Minimising soil contamination in the feed to ensure longterm animal health and performance.
- Protecting the sward to ensures consistently high-value mix of grass and herb species.



Annette Jilg works in the Crop Farming and Feed Storage section of the Baden-Württemberg Agricultural Centre for Cattle, Crop, Dairy and Deer Farming and Fisheries (LAZBW) in Aulendorf, and knows just how important a low foreign material content is for high feed quality.



New arrivals –
at the top end of the family.



LINER 1900.

The LINER 1900, with a working width of 8.05 m and rotor diameter of 3.80 m, is the largest, highest-performance side swather. It is ideal for all professional silage businesses and farm contractors. By combining two swaths, material from a working width of up to 16 m can easily be formed into a single forage swath. To avoid forage losses, the rotor overlap is infinitely adjustable from the driver's seat in the tractor. The four-wheel rotor chassis with steered front wheels and a laterally oscillating front axle ensures exceptionally smooth running and exact gauging of the ground contour, on any kind of terrain. On request, the LINER 1900 can be supplied with a six-wheel rotor chassis with additional tandem axles and trailing wheels for even better ground-contour following, high work speeds and top forage quality.

A brief digression: full LINER dual-rotor range, and standardised model naming conventions.

As is already the case for dual-rotor swathers with central swath laying, dual-rotor side swathers now also come with different rotor diameters. The second digit of the model number always indicates a particular rotor diameter, and the first digit also provides essential information: 2000 models are central swath layers, while 1000 models are side swath layers.

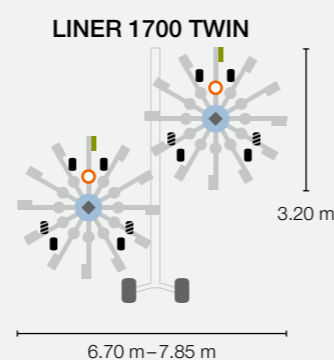
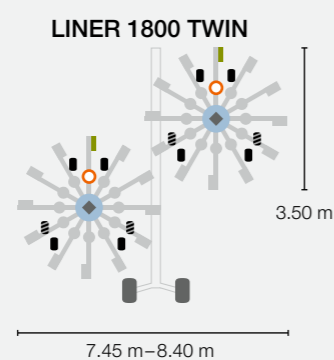
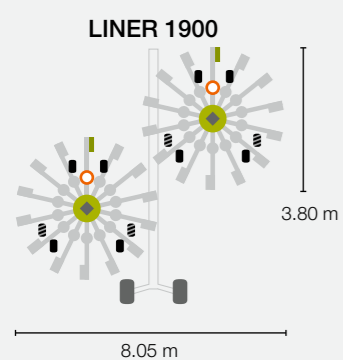

- Silage tines, 9.50 mm
 - PROFIX/20-spline multiple gearing
 - Rotor chassis with 4 or 6 wheels:
 - standard
 - ▨ optional
 - 14-arm rotor dome assembly (permanently lubricated), with triple bearing
 - 12-arm rotor dome assembly (permanently lubricated), with double bearing
 - ◆ Cardanic suspension
- Rotor diameter |
Working width

LINER with side swath laying	LINER with central swath laying	Rotor diameter
1900	2900	3.80 m
1800	2800	3.50 m
1700	2700	3.20 m
1600	2600	2.90 m

Reliable partners –
professionalism guaranteed.

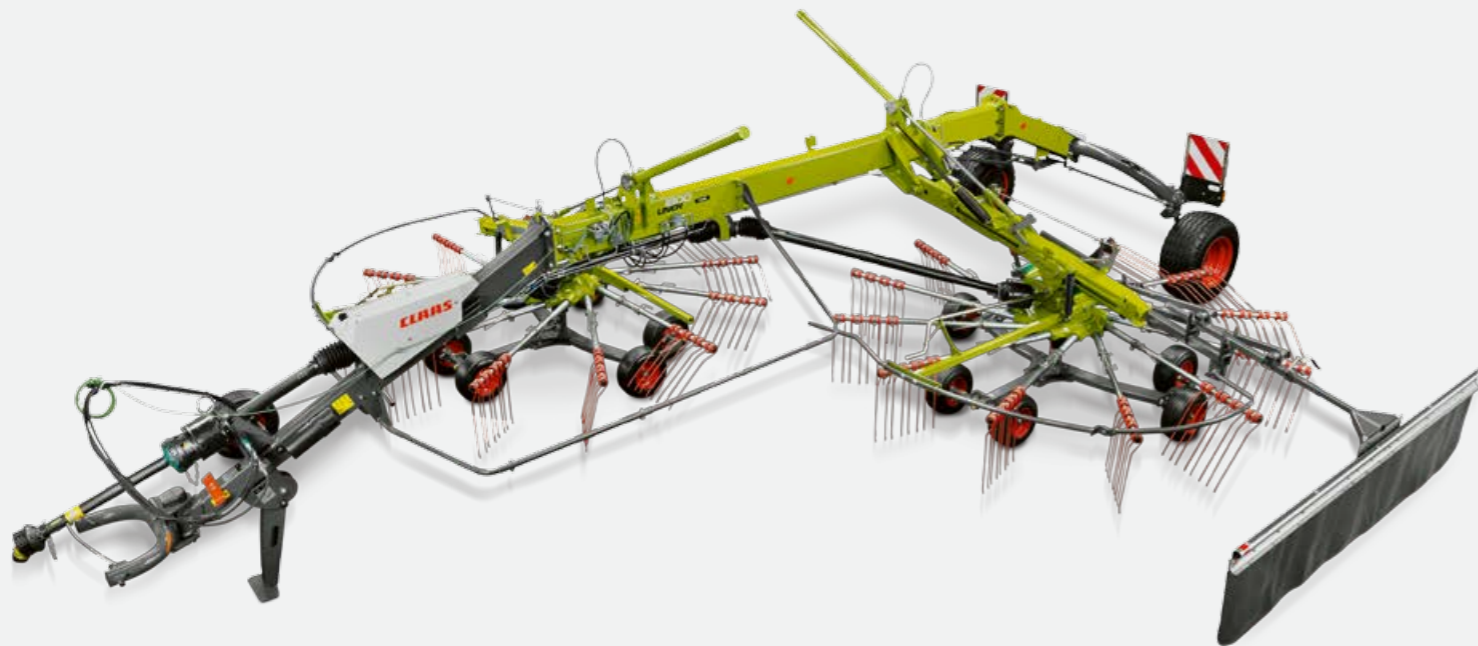

LINER 1800 TWIN and 1700 TWIN. Flexibility guaranteed.

The TWIN function allows for flexible adaptation to a range of different conditions. The two individual swaths can be combined to form a large swath for a forage harvester or baler. You also have the option of forming two smaller swaths for overnight swathing, small self-loading forage wagons, round balers or large forage volumes. You can also opt for hydraulic rake height adjustment to respond quickly to changing harvesting and forage conditions.

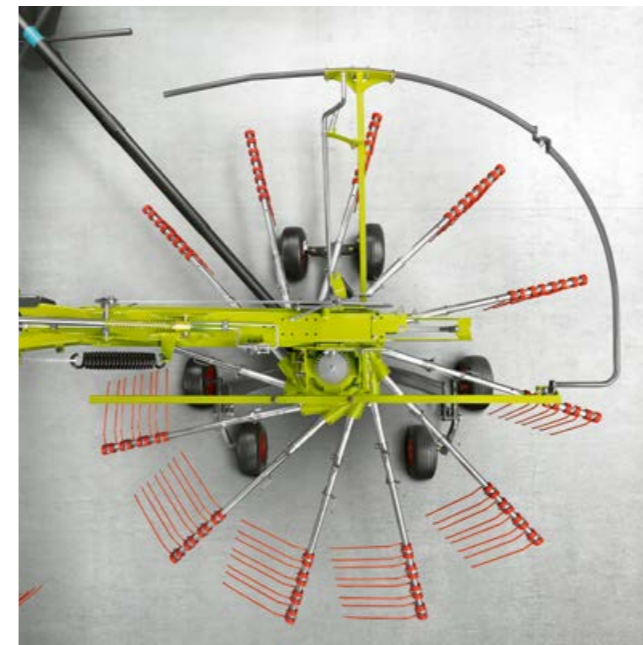

Hydraulic headland stops.

The LINER 1900 and 1800 TWIN models are equipped with an infinitely adjustable hydraulic headland stop. In the LINER 1700 TWIN, this function is performed mechanically, with two positions. The adjustable headland stop can accommodate an incredibly wide range of crop conditions.



Switch from single to double swath.

With the LINER 1800 TWIN and 1700 TWIN, you can switch between single and double swathing simply by relocating the stop bolts on the telescopic booms.



True champions in the hay and straw sector – flexibility is our strength.



Proven LINER reliability.

As well as being consistently reliable, a true hay and straw production champion has to cope confidently with any kind of terrain. The large-size tyres (up to 340/55 R 16) protect soil and sward – whether you decide on a four-wheel chassis, or the six-wheel chassis optionally available for the larger models. You can also opt for hydraulic rake height adjustment, which enables you to respond quickly to changing harvesting and forage conditions.

Flexible inverted U-frame hitch for maximum manoeuvrability.

The flexible inverted U-frame hitch with lateral oscillation allows a steering lock angle of up to 80°. An easy-to-read scale is provided for adjusting the rake height on both of the rotor chassis.

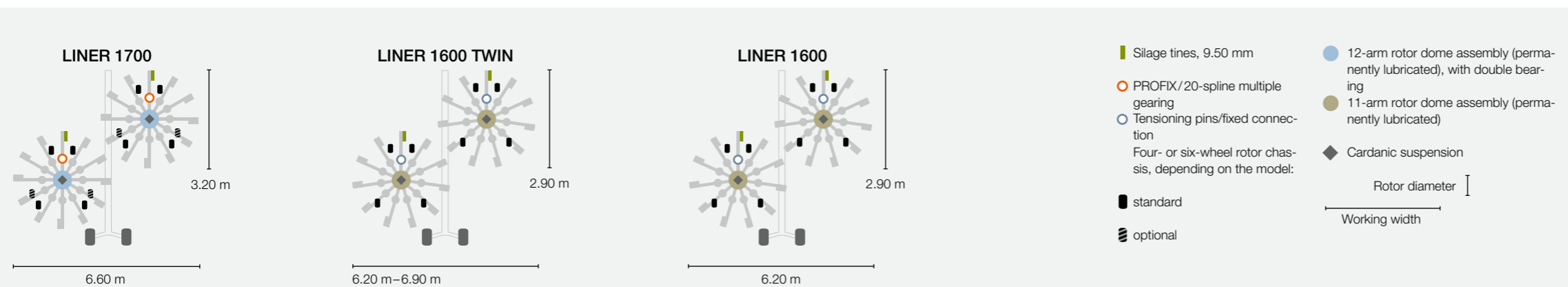

Reliable, safe, low-maintenance – right down to the last detail.



Impeccably shaped swaths, even after the machine has been through.

Optimum swath formation even at the headland, thanks to unparalleled lift heights of 50 cm for the LINER 1900 and LINER 1800, 53 cm for the LINER 1700 and 45 cm for the LINER 1600. Even greater lift heights can be set for double swathing.

Rotor guidance for zero soiling.

Perfectly controlled rotor lift and lowering effectively prevents crop soiling – and eliminates any risk of damage to the sward.



Controlled lift and lowering.

Adjustable hydraulic sequence valve for time-delayed lifting and lowering of the rotors. The lift and lowering speed can also be adjusted to the tractor's hydraulic system.



Safe and low-maintenance.

External drive train and individually secured rotors, low-maintenance 250-h lubrication interval for the universal joints of the drive shafts.



TWIN function.

With the TWIN models, an additional swath guard can be used to rake a double swath (overnight swathing). At haymaking time, for example, this protects already dry material from exposure to moisture at night, before it can be collected.

Unlimited possibilities, taking the toil out of work.



Efficient, high-performance swathing.

The LINER 800 TWIN and 700 TWIN are the ideal harvest partners for small- and medium-sized farms that require productivity at a reasonable price. The impressive features of these swathers include their flexible working width, low power requirement, user-friendly operation and exceptional raking quality. The generously dimensioned chassis and low centre of gravity make both these models very stable on slopes, and gentle on the soil in all types of conditions. And their outstanding steering characteristics also make them ideal for use in grassland orchard areas.

Road transport.

The LINER 700 TWIN folds down to a transport width of less than 3.00 m without removing the tine arms. In the LINER 800 TWIN the rotor diameter is 3.50 m, so the tine arms can be removed for road transport and conveniently stowed securely on the rotor.

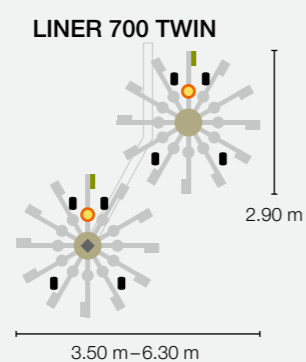
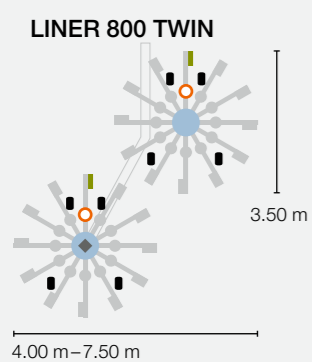

- Silage tines, 9.50 mm
 - PROFIX/20-spline multiple gearing
 - PROFIX/lemon profile
 - Rotor chassis (4-wheel)
 - standard
 - 12-arm rotor dome assembly (permanently lubricated), with double bearing
 - 11-arm rotor dome assembly (permanently lubricated)
 - ◆ Cardanic suspension
- Rotor diameter |
Working width |



Generous lifting height for driving over swaths at headlands: up to 50 cm in the LINER 700 TWIN.



Hydraulic sequential control fitted as standard to adjust the time delay between front and rear rotors when raising and lowering.



Parallelogram drawbar is optional on the LINER 700 TWIN and standard on the LINER 800 TWIN.

Just one rotor, but plenty of performance.

Single-rotor swathers.

The LINER single-rotor swathers are specially developed for farmers who prefer to handle their forage harvesting independently, and who often work in smaller fields. The working widths of 3.20 to 4.80 m are ideal for these situations. Whether with three-point hitching or as a towed model, the key features of the LINER single-rotor swathers are precise ground-contour following, high work rates and outstanding reliability.

LINER 500 PROFIL	4.80 m
LINER 450	4.50 m
LINER 420	4.20 m
LINER 370	3.70 m
LINER 320	3.20 m
LINER 500 T	4.80 m
LINER 450 T	4.50 m



Stand-alone reliability – single-rotor performance.



On the level.

The CLAAS LINER 500 PROFIL was the world's first single-rotor swather with cardanic rotor suspension. Its three-dimensional adaptation to ruts and bumps, independently of tractor movements, has now been adopted in many other models. As an additional benefit, the cardanic suspension means that the rotor remains horizontal during the lifting operation, allowing greater lift heights.

LINER 500 PROFIL

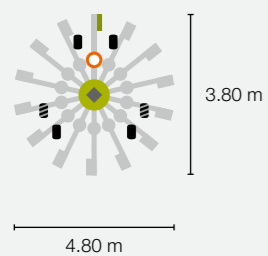

- Silage tines, 9.50 mm
- PROFIX / 20-spline multiple gearing
Rotor chassis with 4 or 6 wheels:
- standard
- ▨ optional
- 14-arm rotor dome assembly (permanently lubricated), with triple bearing
- ◆ Cardanic suspension
- Rotor diameter
- Working width



Effortless removal.

The PROFIX tine arm holder means you can travel safely on the road with the LINER 500, even with the 3.80 m wide rotor dome assembly.

One swather, multiple options – a truly versatile performer.



LINER 450 and 420.

The LINER 450 and 420 models differ only in their working width. As in all CLAAS single-rotor swathers, the maximum lift height ensures well-formed swaths which remain intact even when driven over.

Precision swathing.

The raking height can be adjusted via a crank lever or optionally, hydraulically from the cab, for perfect precision raking. The position of the swath guard can be fixed via an easy-to-operate clamping bolt.

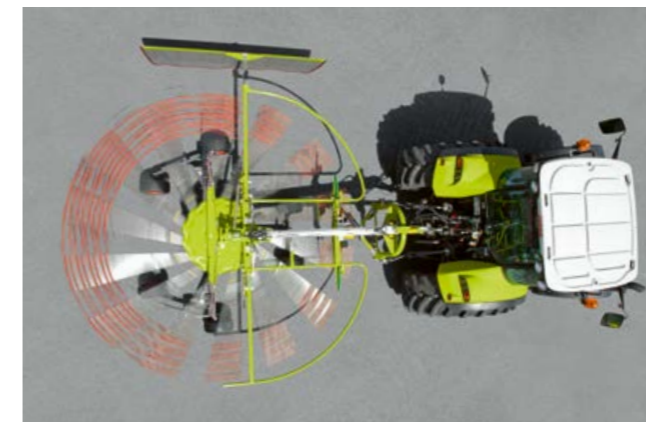
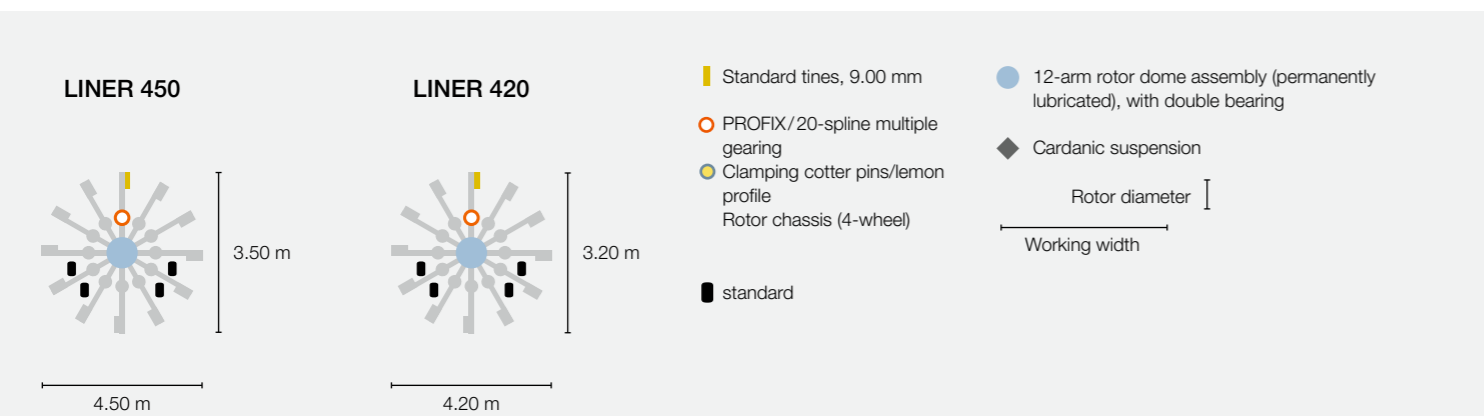

The running gear.

The V-shaped tandem axles are located close to the tine circle of rotation, and provide optimum adaptation to ruts and bumps in the ground. The adjustable lateral inclination is designed to accommodate different crop densities.



Robust inverted U-frame hitch.

Single-rotor swathers are attached to the two lower links of the tractor with the robust inverted U-frame hitch. The high insertion positions for the upper link provide ample ground clearance in the lifted state, even on smaller tractors. The practical support integrated in the inverted U-frame ensures that the universal shaft is at the right height, within easy reach for attachment, and can be conveniently parked when the swather is unhitched.



The 9 mm thick standard tines on the 450, 420, 370 and 320 models are extremely robust, making them ideal for both hay and silage.

Safe and secure on the road.

Standard spring-assisted or optional hydraulically folding protective frames and easy-access transport brackets for removable tine arms make it easy to meet the road transport width requirement. An integrated transport lock holds the rotor in place while on the move, and large warning signs are optionally available, with or without lighting.

The CLAAS power drawbar (CKL) relieves the pressure on the attached swather's carrier frame and the spring-loaded arms prevent overrun on downhill slopes. The arms also automatically lock the three-point frame for safe on-road travel.

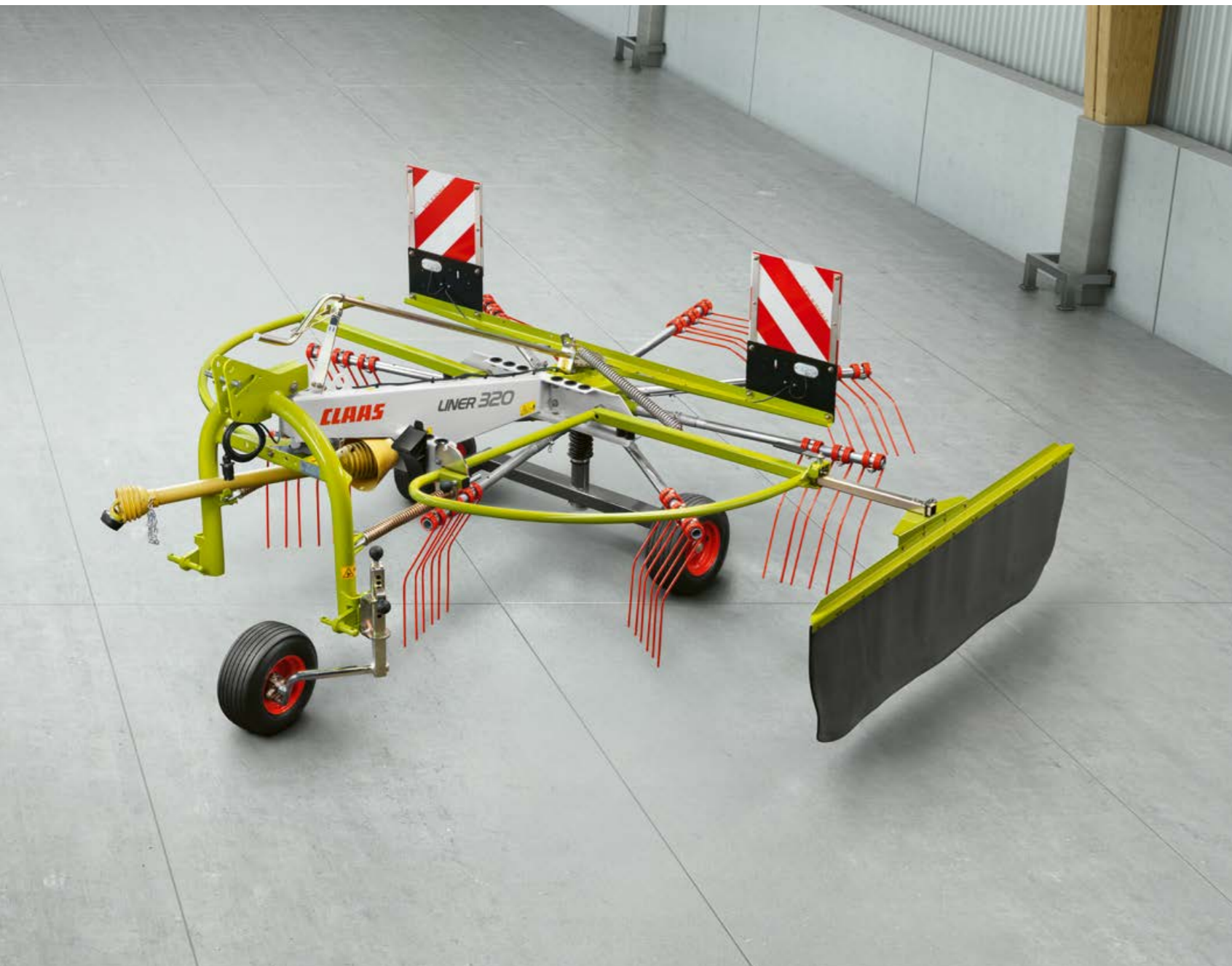

Eight-arm rotor dome assembly in the LINER 320.

The LINER 320 has a maintenance-free eight-arm rotor dome assembly. As on other models, the assembly is hermetically sealed and permanently lubricated, and therefore maintenance-free. The LINER 370 has an 11-arm rotor dome assembly.



Tool-free removal of tine arms.

The tine arms, each with three dual tines, have a lemon profile attachment. They are held securely in place with clamping splints for rapid tool-free removal when required.

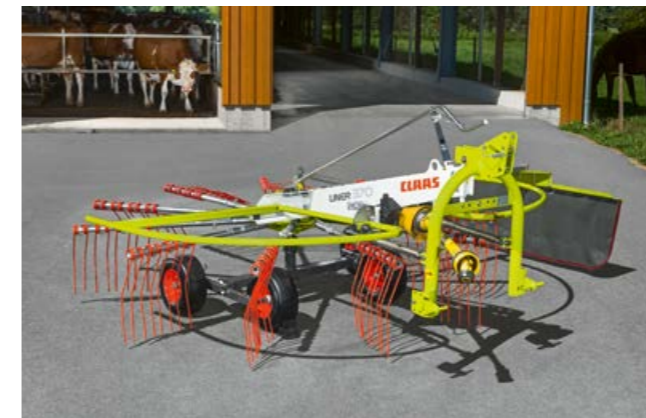

Rotor chassis.

The LINER 370 and 320 both have a single axle as standard. A tandem axle is optionally available. The axles are positioned close to the circle of rotation of the tines for optimum ground-contour following.

LINER 370

LINER 320

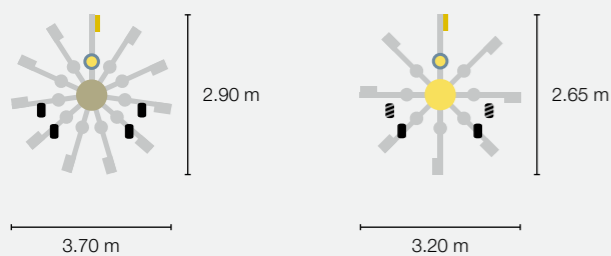

- Standard tines, 9.00 mm
- 11-arm rotor dome assembly (permanently lubricated)
- Clamping cotter pins/lemon profile
- 8-arm rotor dome assembly (permanently lubricated)
- Two- or four-wheel rotor chassis, depending on the model:
- standard
- optional
- ◆ Cardanic suspension
- ⏟ Rotor diameter
- ⏟ Working width



Virtually maintenance-free technology for optimum reliability: the LINER 370 and 320.

An outstanding price-performance ratio combined with long-lasting, virtually maintenance-free technology make these two LINER models the machines of choice in their class.

Power to the rear –
the trailed models.



T is for trailed.

To make the benefits of high-performance swathers available to farms using smaller tractors, CLAAS also supplies two trailed variants: the LINER 500 T and 450 T. Both these LINER models stay in position behind the tractor even in hilly terrain, whether hitched to a linkage drawbar or swinging drawbar.



Just hitch up and drive away.

The trailed single-rotor swather is operated with just one single-acting spool valve.

- The hitch design enables the rotors to be raised parallel to the ground
- The rotor angle in the direction of travel is set with a built-in crank handle fitted in the drawbar cylinder, or the optional gauge wheel
- Optional: parallelogram drawbar for connection to rigid pulling mechanisms



LINER 500 T

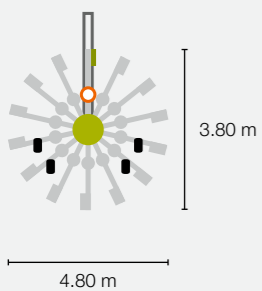

LINER 450 T

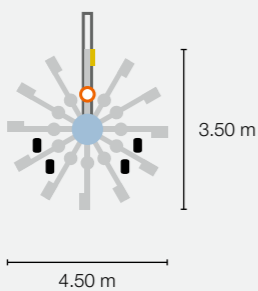

- Silage tines, 9.50 mm
 - Standard tines, 9.00 mm
 - PROFIX/20-spline multiple gearing
 - Rotor chassis (4-wheel)
 - 14-arm rotor dome assembly (permanently lubricated), with triple bearing
 - 12-arm rotor dome assembly (permanently lubricated), with double bearing
 - ◆ Cardanic suspension
- Rotor diameter []
Working width []

Whatever it takes – CLAAS Service & Parts.



CLAAS Service & Parts is always there for you, 24/7.
service.claas.com



Specially matched to your machine.

Precision-manufactured parts, high-quality consumables and useful accessories. Choose our comprehensive product range to be certain of receiving exactly the right solution to ensure 100% operating reliability for your machine.



For your business: CLAAS FARM PARTS.

CLAAS FARM PARTS offers one of the most comprehensive ranges of multi-brand parts and accessories for all agricultural applications on your farm.



Global supply.

The CLAAS Parts Logistics Center in Hamm, Germany, stocks almost 200,000 different parts and has a warehouse area of over 140,000 m². This central spare parts warehouse delivers all ORIGINAL parts quickly and reliably all over the world. This means that your local CLAAS partner can supply the right solution for your harvest or your business within a very short time.



Your local CLAAS distributor.

Wherever you are, you can count on us to always provide you with the service and the contact persons you need. Your CLAAS partners are on hand in your local area, ready to support you and your machine around the clock. With know-how, experience, commitment and the best technical equipment. Whatever it takes.



LINER side swathers ¹		1900	1800 TWIN ²	1700 TWIN ²	1700	1600 TWIN ²	1600	800 TWIN ²	700 TWIN ²	500 PROFIL	450	420	370	320	500 T	450 T
Dual-rotor swathers																
Single-rotor swathers																
Attachment								Swinging draw-bar/hitch	Swinging draw-bar/hitch	Three-point	Three-point/swivelling head	Three-point/swivelling head	Three-point/swivelling head	Three-point/swivelling head	Swinging draw-bar/hitch	Swinging draw-bar/hitch
Hitch category		Cat. II	Cat. II	Cat. II	Cat. II	Cat. II	Cat. II	–	–	Cat. II	Cat. I + II	Cat. I + II	Cat. I + II	Cat. I + II	–	–
Working width	m (DIN)	8.05	7.45–8.40	6.70–7.85	6.60	6.20–6.90	6.20	4.00–7.50	3.50–6.30	4.80	4.50	4.20	3.70	3.20	4.80	4.50
Transport width																
With tine arms mounted	m	2.99	2.99	2.89/2.99	2.89/2.99	2.89/2.99	2.89/2.99	3.60	3.00	3.80 ³	3.50 ³	3.20 ³	2.98 ³	2.80	3.80 ³	3.50 ³
With tine arms removed	m	–	–	–	–	–	–	2.42	2.42	2.40	2.30	2.00	2.22	2.22	2.50	2.20
Transport height																
With tine arms mounted	m	3.99	3.99	3.99	3.99	3.79	3.79	–	–	–	–	–	–	1.52	–	–
With tine arms removed	m	3.69	3.54	3.67	3.67	–	–	–	–	2.45	2.45	2.35	2.15	2.15	2.45	2.45
Parking length (transport position)	m	9.64	9.19	8.66	8.66	8.25	8.25	8.55	8.00	3.30	4.10	3.80	2.55	2.43	4.40	5.25
Weight approx.	kg	2590	2480	2220	2080	1950	1810	1620	1440	805	650	560	450	380	785	660
Rotors	Qty	2	2	2	2	2	2	2	2	1	1	1	1	1	1	1
Rotor diameter	m	3.80	3.50	3.20	3.20	2.90	2.90	3.50	2.90	3.80	3.50	3.20	2.90	2.65	3.80	3.50
Tine arms per rotor	Qty	14	12	12	12	11	11	12	11	14	12	12	11	8	14	12
Dual tines per arm set	Qty	4	4	4	4	4	4	4	4	4	4	4	3 (4 ◊)	3	4	4
Tine diameter	mm	9.50	9.50	9.50	9.50	9.50	9.50	9.50	9.50	9.50	9.00	9.00	9.00	9	9.50	9.00
PROFIX tine arm bracket		●	●	●	●	–	–	●	●	●	●	●	–	–	●	●
Swath-laying position		Left	Left	Left	Left	Left	Left	Left	Left	Left	Left	Left	Left	Left	Left	Left
Two-wheel rotor chassis		–	–	–	–	–	–	–	–	–	–	–	●	●	–	–
Four-wheel rotor chassis		●	●	●	●	●	●	●	●	●	●	●	◊	◊	●	●
Six-wheel rotor chassis		◊	◊	◊	◊	–	–	–	–	◊	–	–	–	–	–	–
Tires																
Rotor chassis	16x6.50-8 10 PR	2x4 (2x6 ◊)	2x4 (2x6 ◊)	2x4 (2x6 ◊)	2x4 (2x6 ◊)	2x4	2x4	–	–	2x4 (2x6 ◊)	4	4	2 (4 ◊)	2 (4 ◊)	–	–
	18x8.50-8 6 PR	–	–	–	–	–	–	2x4	2x4	–	–	–	–	–	4	4
	10.00/75-15.3 10 PR	–	–	●	●	●	●	–	–	–	–	–	–	–	–	–
Main frame	380 /55 - 17	●	●	–	–	–	–	–	–	–	–	–	–	–	–	–
	340/55-16	–	–	◊	◊	◊	◊	–	–	–	–	–	–	–	–	–
Fully floating suspension		●	●	●	●	●	●	● ⁴	● ⁴	●	–	–	–	–	–	–
Drive systems																
PTO shaft speed	rpm	540	540	540	540	540	540	540	540	540	540	540	540	540	540	540
Single wide-angle PTO drive shaft		●	●	●	●	●	●	●	●	–	–	–	–	–	●	●
Convenience																
Spare wheel 16x6.50-8 10 PR		◊	◊	◊	◊	◊	◊	–	–	–	–	–	–	–	–	–
Spare wheel 18x8.50-8 6 PR		–	–	–	–	–	–	◊	◊	–	–	–	–	–	–	–
Wheel weights		◊	◊	◊	◊	◊	◊	–	–	–	–	–	–	–	–	–
Double wide-angle PTO drive shaft		–	–	–	–	–	–	◊	◊	–	–	–	–	–	–	–
TWIN function		–	●	●	–	●	–	●	●	–	–	–	–	–	–	–
Guide wheel		–	–	–	–	–	–	◊	◊	–	◊	◊	◊	–	◊	◊
1 da each for hydraulic rotor height adjustment and hydraulic swath guard folding		◊	◊	◊	◊	◊ ⁶	◊ ⁶	◊	◊	◊	◊	◊	–	–	◊	◊
Hydraulic rotor height adjustment		–	–	–	–	–	–	–	–	◊	◊	◊	–	–	–	–
Warning sign		–	–	–	–	–	–	–	–	◊	◊	◊	◊	◊	◊	◊
Illuminated warning sign		●	●	●	●	●	●	●	●	◊	◊	◊	◊	◊	◊	◊
Parallelogram drawbar		–	–	–	–	–	–	●	◊	–	–	–	–	–	◊	◊
Hydraulic spool valves		1xsa (+ 1xsa ²)	1xsa (+ 1xsa ²)	1xsa (+ 1xsa ²)	1xsa (+ 1xsa ²)	1xsa	1xsa	1xsa	1xsa	–	–	–	–	–	1xsa	1xsa
		1xda	1xda	1xda	1xda	(1xda ²)	(1xda ²)	1xda	1xda	(2xda ^{5,7})	(2xda ^{5,7})	(2xda ^{5,7})	–	–	(1xda ²)	(1xda ²)

- 1 Swath guard
- 2 TWIN function (option) with additional swath guard for front rotor
- 3 Swath guard and safety frame folded
- 4 Rear only
- 5 Hydraulic swath guard folding
Hydraulic swath guard adjustment
- 6 Hydraulic rotor height adjustment

● standard ◊ optional ◻ available – not available

CLAAS continually develops its products to meet customer requirements. This means that all products are subject to change without notice. All descriptions and specifications in this brochure should be considered approximate and may include optional equipment that is not part of the standard specifications. This brochure is designed for worldwide use. Please refer to your nearest CLAAS dealer and their price list for local specification details. Some protective panels may have been removed to present the function more clearly in photographs. To avoid any risks, you should never remove these protective panels yourself. In this context, please refer to the relevant instructions in the operator's manual.

● standard ◊ optional ◻ available – not available

LINER central swathers		4000	3600	3100	2900	2800	2700	2600	
		Four-rotor swathers		Dual-rotor swathers					
Hitch category		Cat. III	Cat. II	Cat. II	Cat. II	Cat. II	Cat. II	Cat. II	
Working width	m (DIN)	12.20–15.00	9.90–12.70	8.70–10.00	8.00–9.00	7.40–8.20	6.80–7.40	6.20–6.80	
Swath width ^{1 ca.}	m	1.50–2.60	1.20–2.30	1.50–2.60	1.20–2.40	1.20–2.20	1.20–2.00	1.10–1.80	
Transport width									
With tine arms mounted	m	3.00	3.00	2.97	2.97	2.97	2.97	2.97	
Transport height									
With tine arms mounted	m	3.99	3.99 ²	4.46	3.99	3.99	3.99	3.99	
With tine arms removed	m	3.57	3.40	3.75	3.72	3.47	3.38	3.18	
Parking length (transport position)	m	10.16	8.70	6.92	6.53	6.53	5.87	5.87	
Rotors	Qty	4	4	2	2	2	2	2	
Rotor diameter	m	3.80	3.30	4.20	3.80	3.50	3.20	2.90	
Tine arms per rotor	Qty	14	12	14	14	12	12	11	
Dual tines per arm set	Qty	4	4	5	4	4	4	4	
Tine diameter	mm	9.5	9.5	9.5	9.5	9.5	9	9	
PROFIX tine arm bracket		●	●	●	●	●	●	–	
Swath-laying position		Centre	Centre	Centre	Centre	Centre	Centre	Centre	
Four-wheel rotor chassis		● ³	●	–	● ³	● ³	●	●	
Six-wheel rotor chassis		○ ⁴	–	● ³	○	○	○	–	
Fully floating suspension		●	●	●	●	●	●	●	
Drive systems									
PTO shaft speed	rpm	540	540	540	540	540	540	540	
Single wide-angle PTO drive shaft		●	●	●	●	●	●	●	
Tyres									
Rotor chassis									
16x6.50-8 10 PR		4x4	4x4	2x6	2x4	2x4	2x4	2x4	
Main frame									
10.00/75-15.3 10 PR		–	–	–	–	2	2	2	
500/55-20		–	○	–	–	–	–	–	
620/40 R 22.5		2	○	–	–	–	–	–	
380 /55 - 17		–	2	2	2	○	–	–	
Weight approx.	kg	5480	4600	2880	2250	2050	1900	1600	
Convenience									
Spare wheel 16x6.50-8 10 PR		○	○	○	○	○	○	○	
Wheel weights		–	–	●	○	○	○	–	
Individual rotor lift (three-way valve)		–	–	○	○	○	○	○	
Electrohydraulic individual rotor lift		●	●	○	○	○	–	–	
Electrohydraulic rotor height adjustment		○	○	○	○	○	–	–	
LED working lights		○	○	–	–	–	–	–	
		–	1xsa	1xsa	1xsa	1xsa	1xsa	1xsa	
Hydraulic spool valves		1xsa + fR or LS	1xsa + fR or LS	1xda	1xda	1xda	–	–	

- 1 Depending on forage conditions and engine speed
2 For tyre variant 500/55-20
3 Front lateral suspension
4 For rear pair of rotors

● standard ○ optional □ available – not available



Ensuring a better **harvest.**

CLAAS KGaA mbH
Mühlenwinkel 1
33428 Harsewinkel
Deutschland
Tel. +49 5247 12-0
claas.com