



WHEEL LOADER | 427/437

427 – Operating weight: 13.1-16.5t Gross engine power: 133kW (179hp) Full turn tipping load: 8603kg Standard shovel capacity: 2.4m³

437 – Operating weight: 14.5-17.8t Gross engine power: 136kW (183hp) Full turn tipping load: 9605kg Standard shovel capacity: 2.7m³



A QUALITY PROCESS.

WE KNOW THAT A WHEEL LOADER IS A KEY PART OF THE ON-SITE PROCESS. THAT'S WHY THE JCB 427 AND 437 ARE BUILT ON A FOUNDATION OF QUALITY AND RELIABILITY. THE PROCESSES WE'VE USED THROUGH DESIGN AND MANUFACTURE WILL SAFEGUARD YOUR WORKING PROCESS, HOUR AFTER HOUR, DAY AFTER DAY.

Designed to work hard.

1 Finite element analysis, as well as extensive endurance and rig testing ensure superior structural strength and durability. Cold cell testing guarantees starting performance down to -20°C .

2 The new front chassis is more durable than ever; it's been strengthened with additional ribs and gussets for maximum service life.

Precision machining provides high tolerances and accurate location of pins and bushes.

3 The JCB 427 and 437 can be specified for heavy-duty applications like waste or corrosive material handling.



We use state-of-the-art manufacturing processes like robot machining, precision paint technology and innovative assembly techniques to achieve the very highest levels of quality.



Protecting ancillaries.

4 A solid cast rear counterweight protects the rear of the machine – including the rear lights and cooling pack – from damage.

You can opt for additional guards on the front screen, lights, underbelly and rear grille.

For additional protection, there are impact-resistant fender edges and trims fitted.

Well articulated.

5 Hoses are neatly routed and clamped through the articulation joint, well away from any pinch points.

6 Designed to tolerate both vertical and horizontal loadings, the articulation joint has a heavy-duty centre pin and oversized bush, as well as twin taper roller bearings on the top box joints.

These machines have integral steel fluid tanks for the ultimate in leak protection; a far superior solution to the plastic tanks favoured by some competitors.

The articulation joint on the JCB 427 and 437 has a heavy-duty box section that's much stronger than a single plate with a boss. Steering rams are positioned high up and well protected from possible impact and site damage.



4



5

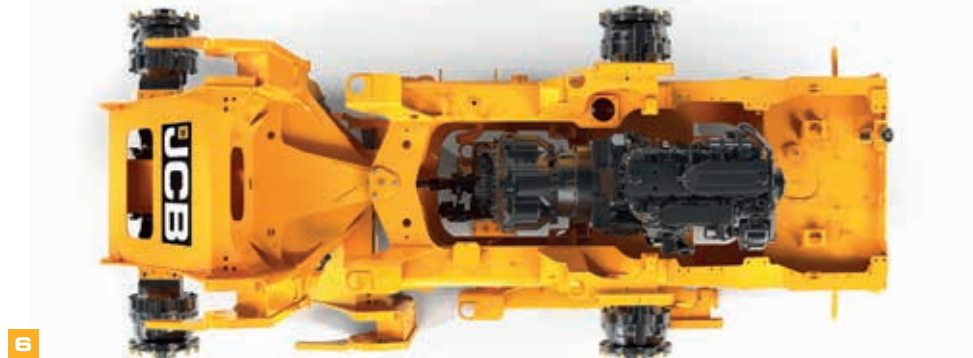

6

PRODUCTIVE PERFORMANCE.

THE 427 AND 437 CAN PERFORM GREAT FEATS OF PRODUCTIVITY. WITH HIGH POWER AND TORQUE, BOTH MACHINES MEET TIER 4 FINAL/STAGE IV EMISSIONS LEGISLATION WITHOUT NEEDING A DPF WHICH ELIMINATES THE NEED FOR PERIODIC REGENERATION.

Drivetrain performance.

1 The Cummins QSB 6.7-litre engine achieves maximum engine power (133kW in the 427, 136kW in the 437) and peak torque (841Nm) at low revs for excellent response.

A variable geometry turbocharger provides increased performance at low engine speed for improved cycle times and tractive effort.

Loading productivity.

2 JCB's optional quickhitch makes attachment changing quick and efficient. The quickhitch is designed to be compatible with aftermarket attachments too.

3 Powerful twin variable displacement piston pump hydraulics can circulate a massive 252 l/min for fast cycles and excellent multi-function capability.

COMMANDPLUS controls.

A choice of 3 or 4-spool hydraulics gives you the scope for invaluable extra versatility. Flow can be adjusted from the cab via the all-new Command Plus controls.

There's no need to worry about wasting time and money replacing a diesel particulate filter (DPF) on your loader; its Cummins engine meets Tier 4 Final/Stage IV legislation using only exhaust gas recirculation (EGR), selective catalytic reduction (SCR) and diesel oxidation catalyst (DOC). This setup also improves fuel economy.



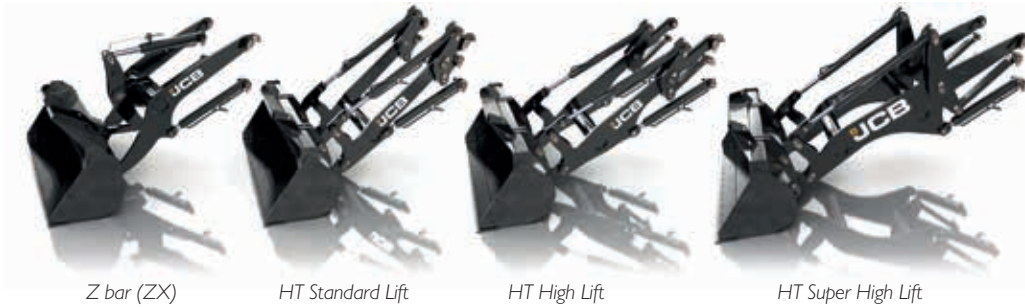

Z bar (ZX)

HT Standard Lift

HT High Lift

HT Super High Lift

4

Loading productivity (continued).

4 You can choose your ideal loader arm on a 427 and 437, with Z-bar linkage (ZX) for high breakout applications or high torque (HT) for parallel lift and multi-attachment use.

Choose a HT high lift on the 427 or 437, or HT super high lift on the 437 and you can use the machine for higher loading height applications.

Drivetrain productivity.

5 The 427 and 437's optional 5-speed transmission with torque convertor lock-up provides closer ratios for better acceleration, hill climbing and roading performance. The lock-up element eliminates losses from the torque converter for faster cycle times and improved efficiency.

5 With a range of axle options, you can tailor performance to any application.

- > Standard differentials are ideal for hard standing ground conditions.
- > Limited slip differentials is perfect for soft, muddy terrain with reduced traction.
- > Open differential with an automatic locking front axle differential provide excellent traction in varied ground conditions.



6



5

The innovative electronic management performs progressive clutch cut-off for efficient, productive loader control. This feature controls tractive effort via the transmission, diverting maximum power to the loader hydraulics and reducing service brake wear and fuel consumption.

EFFICIENT BY DESIGN.

THE JCB 427 AND 437 ARE DESIGNED TO MOVE MORE MATERIAL FOR LESS. TO ACHIEVE THIS, WE'VE DESIGNED THE ENGINE, AXLES, DRIVELINE AND HYDRAULICS TO WORK IN HARMONY WITH EACH OTHER, FOR ULTIMATE EFFICIENCY AND DURABILITY.



Automatic idle returns the engine to 700rpm after 30 seconds of inactivity.

An efficient engine.

- 1 A hydraulic cooling fan automatically reacts to ambient temperature and adjusts the fan speed to optimise energy and reduce fuel consumption. An additional benefit of this setup is reduced noise levels.
- 2 Eco Mode caps engine speed at 1800rpm for reduced fuel consumption. Productivity nonetheless remains formidable.
- 3 Our torque lock-up 5 speed transmission gives you up to 100% efficiency in gears 2 to 5 for improved fuel consumption. Closer gear ratios provide lower engine speed in each gear.



An efficient engine (continued).

- 4 Wheel speed braking means the brakes rotate at the same speed as the wheels for heat and drag reduction, as well as improved fuel economy and access for maintenance and repairs.
- 5 Unloaded spool valves in the valve block mean that arms lower under gravitational, not hydraulic force, reducing fuel consumption.
- 6 JCB's innovative variable displacement pumps feed a load-sensing valve block which only consumes power on demand, providing precise, efficient loader control.
- 7 No DPF means unnecessary additional fuel piping is eliminated as is the potentially dangerous temperatures involved in regeneration. The fuel that would have been needed to restore your DPF can be used instead for actual productive work.



COMMANDPLUS controls.
 JCB Smoothride load suspension limits shock loadings and therefore reduces material spillage and structural stress, as well as increasing operator comfort. The speed of engagement is adjustable from within the cab using the latest state-of-the-art CommandPlus controls.



Adjustable SRS engagement speed.

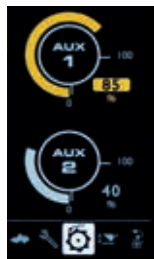

Adjustable Auxiliary control.

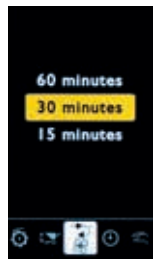

Adjustable reversing fan intervals.



COMMANDPLUS.

THE LATEST JCB 427 AND 437 WHEEL LOADERS BOAST OUR ALL-NEW COMMAND PLUS CAB. THIS UNIQUE APPROACH TO ERGONOMICS IS THE RESULT OF A RADICAL RETHINK AND A RIGOROUS RESEARCH PROGRAMME. EXPECT BEST-IN-CLASS COMFORT, VISIBILITY, ERGONOMICS AND QUIETNESS.

See the difference.

1 You'll immediately notice the totally redesigned ROPS structure; this has allowed the A pillars to be moved to the same width as the rear of the cab, providing a larger interior with a superb panoramic front windscreen. All switches and auxiliary controls are now located on the right-hand A-pillar for easier access.

2 Using your machine's simple, dedicated menu interface is easily done with an intuitive optional rotary controller.

3 Operating your 427 or 437 loader is now easier than ever. All of the controls are seat-mounted, even going as far as to move with the seat suspension. You can also select the control system that's best for your operators: choose from single lever joystick or multi-lever configurations, all using electro-hydraulics for the ultimate in precision.

4 There are two full colour LCD screens to navigate the operating menus, one of which doubles as a monitor for the optional rear-view camera and CommandPlus control menu.



The noise level in the cab is an incredibly low 68dB(a): so quiet you can hardly hear the engine running.

5 To keep the operator environment comfortable for working at all times, we've positively pressurised the cab to eliminate dust and fumes.

6 After extensive research into operator ergonomics, we've devised the Command Driving Position, which boasts the very optimal control layout for a multitude of different driver shapes and sizes available, ranging from an air suspension standard seat to a super deluxe half leather seat, featuring fully adjustable heating and cooling functionality, electrically adjustable lumbar support and adjustable dampers.

7 A set and forget feature makes operator access even easier. In short, your preferred steering wheel position is stored and can be instantly returned to, even after you've folded the wheel away.

Specify your 427 or 437 with either air conditioning or automatic climate control to create perfect working temperatures.

With a dedicated media port on board, you can be assured of superb connectivity for all your electronic devices.

A sliding window on both sides of the cab allows easy communication with people outside the machine.

The electronic handbrake offers numerous advantages: it's quick and easy to operate, and, because there's no cable, there are fewer holes in the cab. This helps to isolate the operator environment further.



LOW MAINTENANCE LONG INTERVALS.

WHEEL LOADERS NEED TO SPEND THE MAXIMUM AMOUNT OF TIME HARD AT WORK. WE'VE DESIGNED THE 427 AND 437 TO DO JUST THAT, WITH LONG SERVICE INTERVALS AND QUALITY COMPONENTS.

Routine maintenance.

- 1 It's easy to get to the engine on a new JCB 427 and 437 with a large automatic opening single-piece bonnet.
- 2 Accessing the diesel and DEF (Diesel Exhaust Fluid) tanks is similarly straightforward via the lockable grille at the rear of the machine.

You can check washer fluid level, engine oil and coolant from inside the cab, with all other routine checks and grease points located at ground level. This makes life both easier and safer.

- 3 Most Tier 4 Final/Stage IV engines use a costly Diesel Particulate Filter (DPF) that can cost a lot of money and time when it needs replacing. The Cummins engine is DPF-free, reducing your servicing and running costs.

- 4 A large single-faced wide-core cooling pack package provides unrivalled quick, easy and safe cleaning.
- 5 With the optional auto lubrication kit, your machine will take care of its own greasing requirements.



Less servicing, more service

5 The CommandPlus cab relays machine condition giving real time alerts, safeguarding both the machine and the operator.

The intuitive CommandPlus help function provides the operator with meaningful descriptions of in-cab switch function. Using the “?” button, this allows new or unfamiliar operators to quickly and easily understand machine functions without having to refer to the operators manual.

6 By using premium components in the 427 and 437 (Cummins engine, ZF transmissions and axles, Rexroth pumps and Parker valve blocks), we've built in long service life as standard.

7 Full hydraulic dual circuit braking with multiple oil immersed discs gives the braking system a virtually maintenance-free lifespan.

A cyclonic engine fan scavenge filter provides four times the filtering capacity of a standard air filter. It's a longer life system, with fewer components and a higher level of efficiency, making for better engine protection. There's a large fuel tank fitted (290 litres on the 427 and 270 litres on the 437) which ensures maximum working hours between refills.

Heating and ventilation filters are conveniently located behind an external access panel. The main fuse board and relays have been repositioned next to the door for easy access.

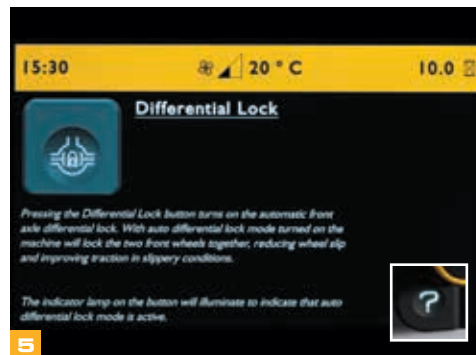

COMMANDPLUS controls.

If you're planning to use your wheel loader in environments with large amounts of airborne debris, opt for the adjustable reversing fan. The fan can be operated via the CommandPlus controls, and even swings out for easy cleaning access.



DRIVE SAFELY.

THE NEW JCB 427 AND 437 ARE DESIGNED TO KEEP THE OPERATOR AND YOUR WORKSITE SAFE AT ALL TIMES. GREAT VISIBILITY, NON-SLIP SURFACES AND FULL ROPS/FOPS PROTECTION ARE JUST THE START.

Safely does it.

- 1 Our optional rear-view camera displays an unobstructed rearward view on the in-cab colour monitor onboard your 427 and 437.
- 2 Superb visibility in dark conditions is guaranteed with JCB's optional LED lighting.
- 3 You'll find the rear-view mirrors mounted in front of the A-pillars for improved all-round visibility.

Interior mirrors, heated exterior mirrors and bonnet mirrors combine to offer excellent views to every corner of your machine.

- 4 Visibility over the rear bonnet is excellent because the air cleaner is underneath the bonnet and the exhaust stack is located centrally.

If you plan to use your wheel loader for quarry work, it's worth specifying options such as blue flashing reverse lights, a green operator presence beacon, a rear object detection system, and hi-viz exterior chevrons.



Safely does it (continued).

5 Access steps on the 427 and 437 are inclined and equally spaced, complemented by well positioned grab handles for three points of contact at all times.

6 Full fender coverage flaps have been carefully designed to keep forward spray to a minimum for all tyre options. This increases safety and decreases debris build-up.

7 Door hinges are now mounted on the A-pillar; this simple change has created much better access via a larger and wider door aperture. It also means you can access the rear of your loader more safely.

The battery and tool box are lockable for added security.

8 The cab is isolator-mounted, compliant with ROPS/FOPS standards, and positively pressurised against dust. You can choose from fresh air or carbon filters as well.

9 Engines fitted with a DPF can pose an increased fire risk because extreme heat can be created in regeneration mode. The new 427 and 437 don't use DPFs, so this is no cause for concern.

Non-slip walkways and additional grab handle options allow for safe movement around the machine.



LIVELINK, WORK SMARTER.

LIVELINK IS AN INNOVATIVE SOFTWARE SYSTEM THAT LETS YOU MANAGE JCB MACHINES REMOTELY – ONLINE, BY EMAIL OR BY MOBILE PHONE. ACCESS EVERYTHING FROM MACHINE ALERTS TO FUEL REPORTS AND HISTORY INFORMATION, WITH ALL DATA STORED AT A SECURE CENTRE.

Productivity and cost benefits

By providing information like idle time monitoring and machine fuel consumption, JCB Livelink helps reduce your fuel usage, saving money and improving productivity. Machine location information can help improve efficiency and perhaps even reduce insurance costs.

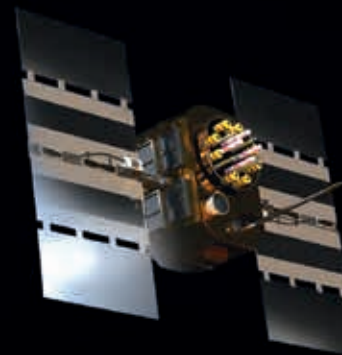

Maintenance benefits

Manage machine maintenance easily – accurate hours monitoring and service alerts improve maintenance planning, while real-time location data helps you manage your fleet. Critical machine alerts and maintenance history records are also available.



Security benefits

Livelink's real-time geofencing alerts tell you when machines move out of predetermined zones, and real-time curfew alerts inform you of unauthorised usage. Further benefits include real-time location information.



A GREAT BUSINESS DECISION.

WE'LL PROVIDE YOU WITH FIRST CLASS SUPPORT AND ASSISTANCE TO SUIT YOUR EXACT BUSINESS NEEDS RIGHT FROM DAY ONE. SO WHEREVER YOU ARE, YOUR MACHINE WILL ALWAYS PERFORM TO ITS FULL POTENTIAL – ONE OF MANY REASONS WHY STARTING A WORKING RELATIONSHIP WITH JCB IS A GREAT BUSINESS DECISION.

Machine selection

Your JCB dealer has the right technical knowledge and expertise to ensure that you assess all the machine options available to you. This includes rental options and new or used machine sales.

Rebuild and Refurbishment Programme

If your business isn't in a position to buy a brand new machine, then JCB's Rebuild and Refurbishment programme can help you to extend the service life of your current vehicle cost-effectively.

Technical support

All local JCB dealers have instant access to factory expertise and technical support to provide you with the maximum machine uptime. JCB's Global Parts Centres, meanwhile, deliver around 95% of all parts anywhere in the world within 24 hours.

Component monitoring

JCB machines benefit from a sophisticated component monitoring programme that provides preventative maintenance and oil sampling to keep everything working at its optimum level.

Service support

We offer a range of extended warranties, from JCB PremierCover (full comprehensive cover) to JCB PowertrainCover (engine, axles, transmission and hydraulic pump cover). Service agreements, as well as service-only or Repair and Maintenance contracts ensure that we have the up-time of your wheel loading shovel totally covered. Our dealer maintenance specialists around the world charge competitive labour rates, and offer non-obligation quotations as well as fast, efficient repair work.

Finance and Insurance

Finance and Insurance specialists are always on-hand to provide fast, flexible, competitive quotes. Naturally, packages can be tailored to suit your specific business needs.

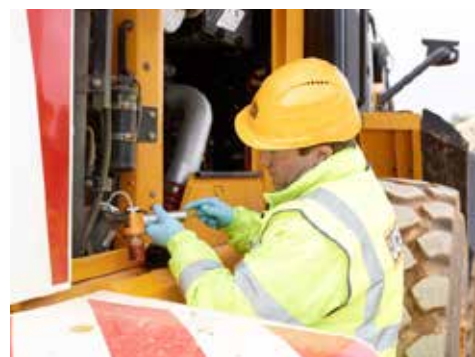

STATIC DIMENSIONS

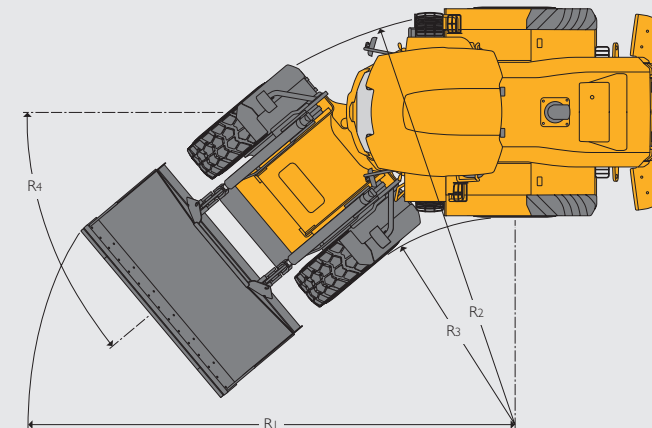
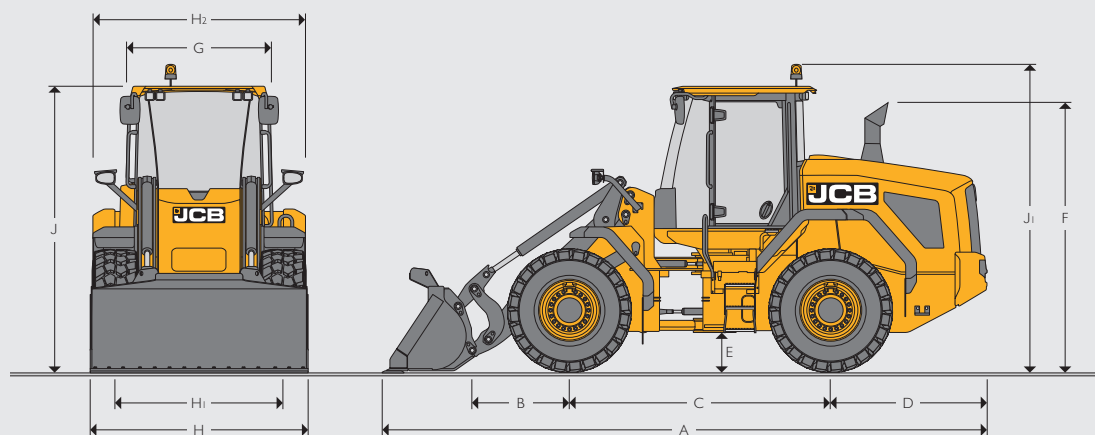

		427 HT	427 HT HL	427ZX	437 HT	437 HT HL	437 HT SHL	437 ZX	
A	Overall length	mm	7070	7532	7069	7301	7928	8485	7306
B	Axle to pivot pin	mm	1134	1596	1108	1246	1873	2430	1251
C	Wheelbase	mm	3050	3050	3050	3050	3050	3050	3050
D	Axle to counterweight face	mm	1833	1833	1833	1833	1833	1833	1833
E	Minimum ground clearance	mm	472	472	472	472	472	472	472
F	Height over exhaust	mm	3133	3133	3133	3133	3133	3133	3133
G	Width over cab roof	mm	1594	1594	1594	1594	1594	1594	1594
H	Max. width	mm	2483	2483	2483	2598	2598	2598	2598
H1	Wheel track	mm	1955	1955	1953	2070	2070	2070	2070
H2	Max width over fenders	mm	2484	2484	2477	2560	2560	2560	2556
J	Height over cab roof and lowered beacon	mm	3360	3360	3360	3360	3360	3360	3360
J1	Height over raised beacon	mm	3720	3720	3720	3720	3720	3720	3720
	Front axle weight	kg	5888	6926	6281	6831	7415	8818	7441
	Rear axle weight	kg	7493	6654	7373	7966	7801	6848	7786
	Total weight	kg	13381	13580	13654	14797	15216	15666	15227
	Height over engine cover from ground fully open	mm	3611	3611	3611	3611	3611	3611	3611
	Increase in vehicle length with bonnet open (rear grille shut)	mm	+928	+928	+928	+928	+928	+928	+928

		427HT	427 HT HL	427ZX	437 HT	437 HT HL	437 HT SHL	437 ZX	
R1	Maximum turn radius over shovel	mm	5902	6035	5933	6021	6286	6626	6041
R2	Maximum turn radius over tyre	mm	5483	5483	5483	5483	5483	5483	5483
R3	Inside turn radius	mm	2896	2896	2896	2896	2896	2896	2896
R4	Articulation angle	degrees	40	40	40	40	40	40	40

427 based on a machine equipped with Michelin 20.5R25 XHA2 (L3) radial tyres & direct mount 1.9m³ shovel and toe plates & standard counterweight.
 437 based on a machine equipped with Michelin 20.5R25 XHA2 (L3) radial tyres & direct mount 2.3m³ shovel and toe plates & standard counterweight.

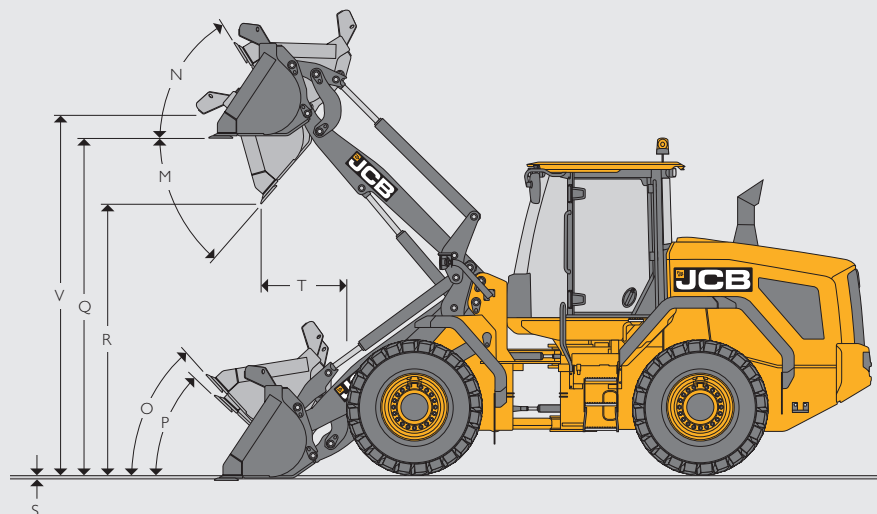

TYRE SIZE 427 HT/HT HL

Tyre size	Manufacturer	Type	Rating	Operating weight (kg)	HT		HT HL		Dimensions	
					STL kg	F TTL kg	STL kg	F TTL kg	Vertical mm	Width mm
20.5R25	MICHELIN	XHA2	L3	0	0	0	0	0	0	0
20.5R25	MICHELIN	XTLA	L2	-116	-82	-71	-70	-42	-7	4
20.5R25	MICHELIN	XLDD2A	L5	492	346	299	296	180	30	6
20.5R25	MICHELIN	XMINED2	L5	652	459	397	392	239	58	34
550/65R25	MICHELIN	XLDD2A	L3	-72	-51	-44	-43	-26	-44	21
20.5R25	MICHELIN	XSNOPPLUS	L2	-60	-42	-37	-36	-22	-11	6
620/75R26	MICHELIN	MEGAXBIB	N/A	-248	-175	-151	-149	-91	68	108
650/65R25	MICHELIN	XLD	L3	652	459	397	392	239	-10	249
750/65R26	MICHELIN	MEGAXBIB	N/A	4	3	2	2	1	81	474
20.5-25	G/YEAR	SGL (16 ply)	L2	-200	-141	-122	-120	-73	-5	4
20.5-25	G/YEAR	HRL (16 ply)	L3	4	3	2	2	1	37	4
20.5R25	G/YEAR	TL-3A+	L3	272	192	166	164	100	11	4
20.5R25	G/YEAR	RL-5K	L5	776	546	472	467	284	49	4
20.5R25	JCB	Earthmover	L3	128	90	78	77	47	41	12
20.5-25	SG REVOLUTION	SE	N/A	2068	1456	1258	1243	757	17	95
20.5-25	SG REVOLUTION	S2 C2 DWL	N/A	2192	1543	1334	1318	802	6	95
20.5-25	JCB	Sitemaster (16ply)	L3	100	70	61	60	37	21	-7
20.5R25	NOKIAN	GRIP TL	L3	-200	-141	-122	-120	-73	4	-7

Heavy duty axles (required with 6 speed, solid/foam filled tyres, 750 width agricultural tyres and high lift arms).

LOADER DIMENSIONS 427 HT/HT HL

Model	427 HT												427 HT HL												
	Direct						Quickhitch						Direct						Quickhitch						
	General purpose						General purpose						General purpose						General purpose						
Shovel mounting	Tipped teeth						Reversible toeplate						Tipped teeth						Reversible toeplate						
Shovel type	Tipped teeth						Reversible toeplate						Tipped teeth						Reversible toeplate						
Shovel equipment	Tipped teeth						Reversible toeplate						Tipped teeth						Reversible toeplate						
Shovel capacity (SAE heaped 100%)	m ³	1.8	2	1.9	2.1	2.4	2.7	1.8	2	1.9	2.1	2.4	2.7	1.8	2	1.9	2.1	2.4	2.7	1.8	2	1.9	2.1	2.4	2.7
Shovel capacity (struck)	m ³	1.556	1.765	1.616	1.83	2.057	2.346	1.554	1.749	1.594	1.787	2.057	2.346	1.556	1.765	1.616	1.83	2.057	2.346	1.554	1.749	1.594	1.787	2.057	2.346
Shovel width	mm	2550	2550	2550	2550	2700	2700	2550	2550	2550	2550	2700	2700	2550	2550	2550	2550	2700	2700	2550	2550	2550	2550	2700	2700
Shovel weight	kg	810	850	810	850	1136	1211	800	850	800	850	1136	1211	810	850	810	850	1136	1211	800	850	800	850	1136	1211
Maximum material density *	kg/m ³	2633	2346	2494	2234	1901	1667	2438	2172	2310	2069	1761	1544	2219	1977	2102	1883	1595	1398	2058	1833	1949	1746	1479	1296
Tipping load straight *	kg	11038	10932	11038	10932	10666	10530	10260	10162	10260	10162	9921	9793	9316	9228	9316	9228	8971	8856	8677	8598	8677	8598	8358	8247
Tipping load full turn *	kg	9478	9382	9478	9382	9124	9000	8778	8688	8778	8688	8455	8337	7988	7907	7988	7907	7657	7550	7407	7334	7407	7334	7102	6999
Payload *	kg	4739	4691	4739	4691	4562	4500	4389	4344	4389	4344	4228	4168	3994	3953	3994	3953	3828	3775	3704	3667	3704	3667	3551	3499
Maximum breakout force	kN	138	128	138	128	123	115	121	113	121	113	106	99	138	128	138	128	123	115	121	113	121	113	106	99
M Dump angle maximum	degrees	49	49	49	49	49	49	49	49	49	49	49	49	45	45	45	45	45	45	45	45	45	45	45	45
N Roll back angle full height	degrees	58	58	58	58	58	58	58	58	58	58	58	58	58	58	58	58	58	58	58	58	58	58	58	58
O Roll back at carry	degrees	48	48	48	48	48	48	48	48	48	48	48	48	50	50	50	50	50	50	50	50	50	50	50	50
P Roll back at ground level	degrees	43	43	43	43	43	43	43	43	43	43	43	43	48	48	48	48	48	48	48	48	48	48	48	48
Q Load over height	mm	3627	3627	3612	3612	3610	3610	3627	3627	3612	3612	3610	3610	4057	4057	4042	4042	4040	4040	4057	4057	4042	4042	4040	4040
R Dump height (45 deg dump)	mm	2871	2767	2944	2896	2860	2796	2697	2647	2848	2775	2739	2676	3247	3197	3374	3326	3290	3226	3212	3127	3278	3205	3169	3106
S Dig depth	mm	50	50	47	47	47	47	50	50	47	47	47	47	113	113	110	110	110	110	128	113	110	110	110	110
T Reach at dump height	mm	1022	1072	897	963	979	1043	1142	1191	1003	1069	1100	1164	1184	1934	1059	1109	1141	1205	1195	1204	1165	1231	1262	1326
V Pin height	mm	3876	3876	3876	3876	3876	3876	3876	3876	3876	3876	3876	3876	4306	4306	4306	4306	4306	4306	4306	4306	4306	4306	4306	4306
Reach maximum (45 deg dump) horizontal arm	mm	1769	1819	1644	1694	1726	1790	1889	1938	1751	1816	1847	1911	2117	2167	1992	2042	2074	2138	2128	2237	2099	2164	2195	2259
Operating weight (includes 75kg operator and full fuel and DEF tanks)	kg	13381	13425	13381	13425	13685	13748	13676	13720	13676	13720	13957	14019	13591	13635	13591	13635	13895	13958	13886	13930	13886	13930	14167	14229

*Assumes machine is fitted with Michelin 20.5R25 XHA2 (L3) tyres, 5 speed transmission and non parallel links.

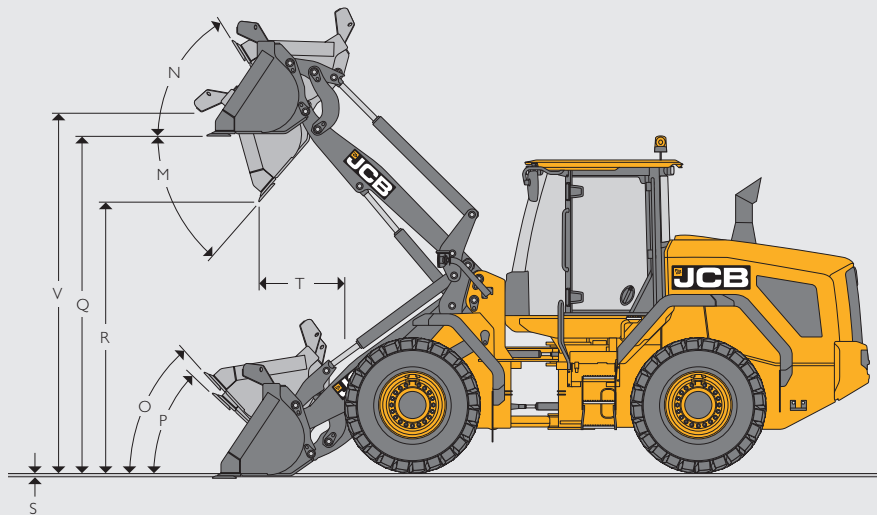

TYRE SIZE 437 HT/HT HL/HT SHL

Tyre size	Manufacturer	Type	Rating	Operating weight (kg)	HT		HT HL		HT SHL		Dimensions	
					STL kg	F TTL kg	STL kg	F TTL kg	STL kg	F TTL kg	Vertical mm	Width mm
20.5R25	MICHELIN	XHA2	L3	0	0	0	0	0	0	0	0	0
20.5R25	MICHELIN	XTLA	L2	-116	-78	-67	-63	-37	-36	-25	-7	4
20.5R25	MICHELIN	XLDD2A	L5	-72	-48	-42	-39	-23	-22	-16	-44	21
20.5R25	MICHELIN	XMINED2	L5	-76	-51	-44	-41	-24	-24	-17	-11	6
550/65R25	MICHELIN	XLDD2A	L3	492	330	285	269	156	153	107	30	6
20.5R25	MICHELIN	XSNOPUS	L2	652	438	378	356	206	203	142	58	34
620/75R26	MICHELIN	MEGAXBIB	N/A	-248	-166	-144	-135	-79	-77	-54	68	-7
650/65R25	MICHELIN	XLD	L3	652	438	378	356	206	203	142	-10	134
750/65R26	MICHELIN	MEGAXBIB	N/A	4	3	2	2	1	1	1	81	359
20.5-25	G/YEAR	SGL (16 ply)	L2	-200	-134	-116	-109	-63	-62	-44	-5	26
20.5-25	G/YEAR	HRL (16 ply)	L3	272	183	158	148	86	85	59	11	17
20.5R25	G/YEAR	TL-3A+	L3	776	521	450	424	246	241	170	49	26
20.5R25	G/YEAR	RL-5K	L5	4	3	2	2	1	1	1	37	26
20.5R25	BKT	XL GRIP	L3	128	86	74	70	41	40	28	41	12
20.5-25	SG REVOLUTION	SE	N/A	2068	1388	1199	1129	655	643	452	17	-20
20.5-25	SG REVOLUTION	S2 C2 DWL	N/A	2192	1471	1271	1197	694	681	479	6	-20
20.5-25	JCB	Sitemaster (16ply)	L3	100	67	58	55	32	31	22	21	-7
20.5R25	NOKIAN	GRIP TL	L3	-200	-134	-116	-109	-63	-62	-44	4	-7
Optional Heavy Duty Counterweight (Not available with solid cushion tyres)				312	642	580	527	476	435	393	-	-

STL & F TTL figures based on 2.6m DM bucket.

LOADER DIMENSIONS 437 HT/HT HL

Model	437 HT								437 HT HL								437 HT SHL								
	Direct				Quickhitch				Direct				Quickhitch				Direct				Quickhitch				
Shovel mounting	General purpose								General purpose								General purpose								
Shovel type	Tipped teeth		Reversible toeplate		Tipped teeth		Reversible toeplate		Tipped teeth		Reversible toeplate		Tipped teeth		Reversible toeplate		Tipped teeth		Reversible toeplate		Tipped teeth		Reversible toeplate		
Shovel equipment																									
Shovel capacity (SAE heaped 100%)	m ³	2.3	2.6	2.4	2.7	2.3	2.6	2.4	2.7	2.3	2.6	2.4	2.7	2.3	2.6	2.4	2.7	2.3	2.6	2.4	2.7	2.3	2.6	2.4	2.7
Shovel capacity (struck)	m ³	1.984	2.27	2.057	2.346	1.984	2.27	2.057	2.346	1.984	2.27	2.057	2.346	1.984	2.27	2.057	2.346	1.984	2.27	2.057	2.346	1.984	2.27	2.057	2.346
Shovel width	mm	2740	2740	2700	2700	2740	2740	2700	2700	2740	2740	2700	2700	2740	2740	2700	2700	2740	2740	2700	2700	2740	2740	2700	2700
Shovel weight	kg	1151	1224	1163	1236	1124	1199	1136	1211	1151	1224	1163	1236	1124	1199	1136	1211	1151	1224	1163	1236	1124	1199	1136	1211
Maximum material density *	kg/m ³	2015	1759	1931	1694	1872	1634	1794	1573	1617	1412	1550	1359	1506	1314	1444	1265	1174	1021	1125	983	1080	938	1035	904
Tipping load straight *	kg	10953	10819	10953	10819	10216	10088	10216	10088	8828	8722	8828	8722	8264	8161	8264	8161	6468	6367	6468	6367	5995	5898	5995	5898
Tipping load full turn *	kg	9270	9148	9270	9148	8612	8495	8612	8495	7440	7341	7440	7341	6929	6833	6929	6833	5402	5308	5402	5308	4970	4880	4970	4880
Payload *	kg	4635	4574	4635	4574	4306	4248	4306	4248	3720	3671	3720	3671	3464	3417	3464	3417	2701	2654	2701	2654	2485	2440	2485	2440
Maximum breakout force	kN	147	134	147	134	131	122	131	122	147	134	147	134	131	122	131	122	153	139	153	139	136	124	136	127
M Dump angle maximum	degrees	49	49	49	49	49	49	49	49	45	45	45	45	45	45	45	45	50	50	50	50	50	50	50	50
N Roll back angle full height	degrees	58	58	58	58	58	58	58	58	60	60	60	60	60	60	60	60	58	58	58	58	58	58	58	58
O Roll back at carry	degrees	48	48	48	48	48	48	48	48	54	54	54	54	54	54	54	54	48	48	48	48	48	48	48	48
P Roll back at ground level	degrees	43	43	43	43	43	43	43	43	45	45	45	45	45	45	45	45	43	43	43	43	43	43	43	43
Q Load over height	mm	3760	3760	3755	3755	3760	3760	3755	3755	4414	4414	4409	4409	4414	4414	4409	4409	4981	4981	4976	4976	4981	4981	4976	4976
R Dump height (45 deg dump)	mm	2794	2730	2962	2871	2709	2645	2850	2786	3448	3384	3616	3525	3363	3299	3504	3440	4011	3947	4179	4088	3926	3862	4067	4003
S Dig depth	mm	132	132	106	106	132	132	106	106	127	127	101	101	127	127	101	101	105	105	79	79	105	105	79	79
T Reach at dump height	mm	1115	1174	1011	1070	1192	1250	1088	1146	1115	1174	1011	1070	1192	1250	1088	1146	1139	1198	1035	1094	1216	1274	1112	1197
V Pin height	mm	4021	4021	4021	4021	4021	4021	4021	4021	4675	4675	4675	4675	4675	4675	4675	4675	5242	5242	5242	5242	5242	5242	5242	5242
Reach maximum (45 deg dump) horizontal arm	mm	1954	2018	1850	1914	1739	2103	1935	1999	2444	2508	2340	2404	2229	2593	2425	2489	2919	2983	2815	2879	2704	3068	2900	2964
Operating weight (includes 75kg operator and full fuel and DEF tanks)	kg	14797	14860	14797	14860	15069	15131	15069	15131	15216	15279	15216	15279	15488	15550	15488	15550	15666	15729	15666	15729	15938	16000	15938	16000

*Assumes machine is fitted with Michelin 20.5R25 XHA2 (L3) tyres, 5 speed transmission and non parallel links.

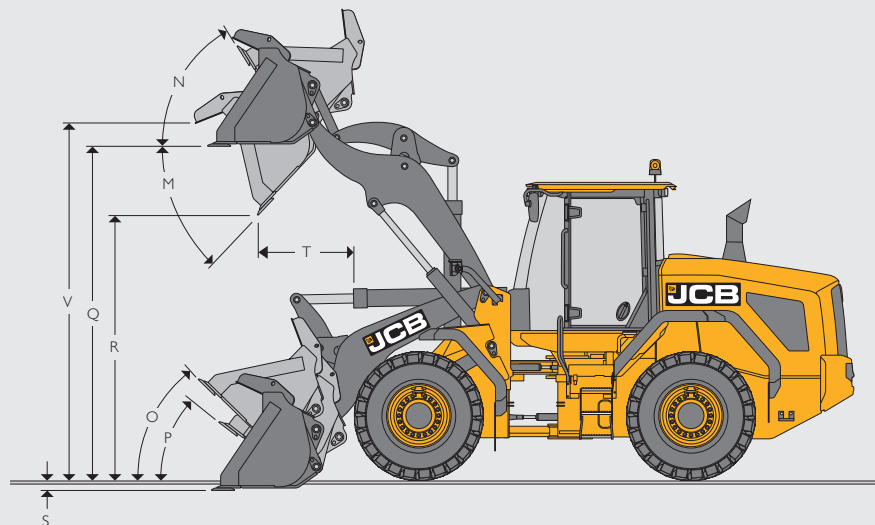

TYRE SIZE 427 ZX					ZX		Dimensions	
Tyre size	Manufacturer	Type	Rating	Operating weight (kg)	STL kg	F TTL kg	Vertical mm	Width mm
20.5R25	MICHELIN	XHA2	L3	0	0	0	0	0
20.5R25	MICHELIN	XTLA	L2	-116	-78	-67	-7	4
20.5R25	MICHELIN	XLDD2A	L5	492	330	285	30	6
20.5R25	MICHELIN	XMINED2	L5	652	438	378	58	34
550/65R25	MICHELIN	XLDD2A	L3	492	330	285	-44	21
20.5R25	MICHELIN	XSNOPUS	L2	-60	-40	-35	-11	6
620/75R26	MICHELIN	MEGAXBIB	N/A	-248	-166	-144	68	108
650/65R25	MICHELIN	XLD	L3	652	438	378	-10	249
750/65R26	MICHELIN	MEGAXBIB	N/A	4	3	2	81	474
20.5-25	G/YEAR	SGL (16 ply)	L2	-200	-134	-116	-5	4
20.5-25	G/YEAR	HRL (16 ply)	L3	4	3	2	37	4
20.5R25	G/YEAR	TL-3A+	L3	272	183	158	11	4
20.5R25	G/YEAR	RL-5K	L5	776	521	450	49	4
20.5R25	BKT	XL GRIP	L3	128	86	74	41	12
20.5-25	SG REVOLUTION	SE	N/A	2068	1388	1199	17	95
20.5-25	SG REVOLUTION	S2 C2 DWL	N/A	2192	1471	1271	6	95
20.5-25	JCB	Sitemaster (16ply)	L3	100	67	58	21	-7
20.5R25	NOKIAN	GRIP TL	L3	-200	-134	-116	4	-7

LOADER DIMENSIONS 427 ZX

Model	427 ZX												
	Shovel mounting	Direct						Quickhitch					
		Shovel type	General purpose						General purpose				
Shovel equipment	Tipped teeth		Reversible toeplate				Tipped teeth		Reversible toeplate				
Shovel capacity (SAE heaped 100%)	m ³	2	2	1.9	2.1	2.4	2.7	1.8	2	1.9	2.1	2.4	2.7
Shovel capacity (struck)	m ³	1.724	1.724	1.612	1.785	2.057	2.346	1.554	1.749	1.594	1.787	2.057	2.346
Shovel width	mm	2550	2550	2550	2550	2700	2700	2550	2550	2550	2550	2700	2700
Shovel weight	kg	1040	1140	925	1040	1262	1329	800	850	800	850	1136	1211
Maximum material density *	kg/m ³	2218	2171	2361	2112	1792	1571	2292	2040	2172	1943	1653	1447
Tipping load straight *	kg	10318	10126	10427	10318	10037	9907	9636	9537	9636	9537	9303	9174
Tipping load full turn *	kg	8872	8684	8971	8872	8603	8483	8252	8162	8252	8162	7934	7814
Payload *	kg	4436	4342	4485	4436	4301	4241	4126	4081	4126	4081	3967	3907
Maximum breakout force	kN	135	135	145	135	129	120	126	118	126	118	113	106
M Dump angle maximum	degrees	45	45	45	45	45	45	45	45	45	45	45	45
N Roll back angle full height	degrees	52	52	52	52	52	52	52	52	52	52	52	52
O Roll back at carry	degrees	44	44	44	44	44	44	44	44	44	44	44	44
P Roll back at ground level	degrees	35	35	35	35	35	35	35	35	35	35	35	35
Q Load over height	mm	3645	3645	3640	3640	3638	3638	3645	3645	3640	3640	3638	3638
R Dump height (45 deg dump)	mm	2797	2797	2973	2925	2889	2825	2726	2694	2852	2804	2768	2704
S Dig depth	mm	33	33	30	30	32	32	33	33	30	30	32	32
T Reach at dump height	mm	1111	1111	936	986	1019	1083	1182	1232	1057	1107	1140	1204
V Pin height	mm	3904	3904	3904	3904	3904	3904	3904	3904	3904	3904	3904	3904
Reach maximum (45 deg dump) horizontal arm	mm	1858	1858	1683	1733	1766	1830	1929	1979	1804	1854	1907	1951
Operating weight (includes 75kg operator and full fuel and DEF tanks)	kg	13687	13866	13654	13687	13929	13997	14016	14060	14016	14060	14297	14359

*Assumes machine is fitted with Michelin 20.5R25 XHA2 (L3) tyres and 5 speed transmission.

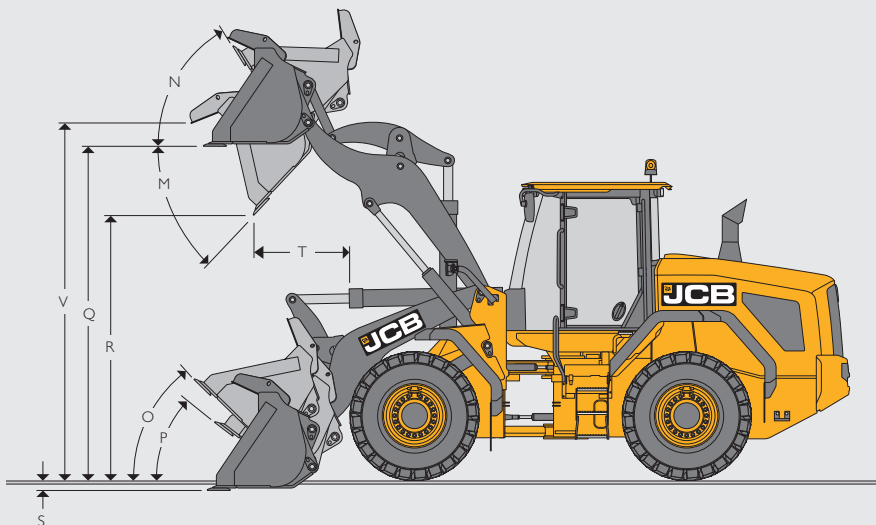

TYRE SIZE 437 ZX

Tyre size	Manufacturer	Type	Rating	Operating weight (kg)	ZX			Dimensions	
					STL kg	FCTL kg	Vertical mm	Width mm	
20.5R25	MICHELIN	XHA2	L3	0	0	0	0	0	
20.5R25	MICHELIN	XTLA	L2	-116	-63	-55	-7	4	
550/65R25	MICHELIN	XLD	L3	-72	-39	-34	-44	21	
20.5R25	MICHELIN	XSNOPPLUS	L2	-60	-33	-28	-11	6	
20.5R25	MICHELIN	XLDD2A	L5	492	269	232	30	6	
20.5R25	MICHELIN	XMINED2	L5	652	356	308	58	34	
620/75R26	MICHELIN	MEGAXBIB	N/A	-248	-135	-117	68	-7	
650/65R25	MICHELIN	XLD	L3	652	356	308	-10	134	
750/65R26	MICHELIN	MEGAXBIB	N/A	4	2	2	81	359	
20.5-25	G/YEAR	SGL (16 ply)	L2	-200	-109	-94	-5	26	
20.5R25	G/YEAR	TL-3A+	L3	272	148	128	11	17	
20.5R25	G/YEAR	RL-5K	L5	776	424	366	49	26	
20.5-25	G/YEAR	HRL (16 ply)	L3	4	2	2	37	26	
20.5R25	BKT	XL GRIP	L3	128	70	60	41	12	
20.5-25	SG REVOLUTION	SE	N/A	2068	1129	976	17	-20	
20.5-25	SG REVOLUTION	S2 C2 DWL	N/A	2192	1197	1034	6	-20	
20.5-25	JCB	Sitemaster (16ply)	L3	100	55	47	21	-7	
20.5R25	NOKIAN	GRIP TL	L3	-200	-109	-94	4	-7	
Optional Heavy Duty Counterweight (Not available with solid cushion tyres)				312	646	584	-	-	

LOADER DIMENSIONS 437 ZX

Model		437 ZX								
		Direct				Quickhitch				
Shovel type		General purpose				General purpose				
Shovel equipment		Tipped teeth		Reversible toeplate		Tipped teeth		Reversible toeplate		
Shovel capacity (SAE heaped 100%)	m³	2.3	2.6	2.6	2.4	2.7	2.3	2.6	2.4	2.7
Shovel capacity (struck)	m³	1.984	2.274	2.274	2.057	2.346	1.984	2.274	2.057	2.346
Shovel width	mm	2740	2740	2740	2700	2700	2740	2740	2700	2700
Shovel weight	kg	1250	1317	1361	1262	1329	1124	1199	1136	1211
Maximum material density *	kg/m³	1980	1735	1689	1897	1671	1838	1603	1761	1544
Tipping load straight *	kg	10663	10548	10328	10663	10548	9947	9820	9947	9820
Tipping load full turn *	kg	9107	9021	8785	9107	9021	8454	8338	8454	8338
Payload *	kg	4554	4511	4392	4554	4511	4227	4169	4227	4169
Maximum breakout force	kN	176	162	162	176	162	157	144	157	144
M Dump angle maximum	degrees	45	45	45	45	45	45	45	45	45
N Roll back angle full height	degrees	52	52	52	52	52	52	52	52	52
O Roll back at carry	degrees	44	44	44	44	44	44	44	44	44
P Roll back at ground level	degrees	35	35	35	35	35	35	35	35	35
Q Load over height	mm	3760	3760	3760	3755	3755	3760	3760	3755	3755
R Dump height (45 deg dump)	mm	2841	2776	2776	2982	2900	2756	2691	2897	2765
S Dig depth	mm	131	131	131	105	105	131	131	105	105
T Reach at dump height	mm	1151	1225	1215	1047	1006	1236	1300	1132	1091
V Pin height	mm	4021	4021	4021	4021	4021	4021	4021	4021	4021
Reach maximum (45 deg dump) horizontal arm	mm	1903	1967	1967	1799	1850	1980	2044	1876	1927
Operating weight (includes 75kg operator and full fuel and DEF tanks)	kg	15227	15295	15495	15227	15295	15595	15657	15595	15657

*Assumes machine is fitted with Michelin 20.5R25 XHA2 (L3) tyres and 5 speed transmission.

ENGINE		427	437
Type		Cummins	
Model		QSB	
Capacity	litres	6.7	
Aspiration		Turbo Charged	
Cylinders		6	
Max gross power to SAE J1995/ISO 14396	kW (hp)	133 (179) @ 1700 rpm	136 (183) @ 2000 rpm
Rated gross power to SAE J1995/ISO 14396	kW (hp) @ 2100rpm	118 (158)	129 (173)
Nett power to ISO 9249	kW (hp) @ 2100rpm	109 (146)	120 (161)
Max torque	Nm @ 1500rpm	841	
Valves per cylinder		4	
Air cleaner		Cyclonic pre filter with engine fan scavenge system	
Fan drive type		Hydraulically driven cooling fan	
Emissions		EU Stage IV, US EPA Tier 4F	

TRANSMISSION		427		427		437		437	
		4 speed non-lock up converter		5 speed with lock up converter (optional)		4 speed non-lock up converter		5 speed with lock up converter (optional)	
Type		ZF							
Model		4WG160		5WG160		4WG190		5WG190	
		Forward	Reverse	Forward	Reverse	Forward	Reverse	Forward	Reverse
1	kph	6.6	6.9	6.8	7.2	6.68	7.06	6.86	7.25
2	kph	13.1	13.8	12.5	13.1	12.77	13.43	12.37	13.03
3	kph	23.5	24.7	19.2	30.1	24.51	25.66	18.66	29.33
4	kph	38.5		28.6		37.83		28.02	
5	kph			40.0				39.72	

Please note the above data is based on Michelin 20.5R25 XHA2 (L3) tyres, figures may vary depending on tyres fitted.

AXLES		427	
Model		427	
Type		Standard	Heavy duty
Make and model		ZF MT-L 3075 II (front), ZF MT-L 3075 II (rear)	ZF MT-L 3085 II (front), ZF MT-L 3075 II (rear)
Overall axle ratio		21.53 : 1	
Rear axle oscillation		+/- 10.5 Degrees	
Model		437	
Type		Heavy duty	
Make and model		ZF MT-L 3085 II (front), ZF MT-L3085 II (rear)	
Overall axle ratio		20.182:1	
Rear axle oscillation		+/- 10.5 Degrees	

ELECTRICAL SYSTEM		
System voltage	Amps	24
Alternator output	Amps	120
Battery capacity	Amp hour	110

HYDRAULICS		427	437
Pump type		Variable displacement	
Pump 1 max. flow	l/min	126	126
Pump 1 max. pressure	bar	250	250
Pump 2 max. flow	l/min	126	126
Pump 2 max. pressure	bar	160	160
Hydraulic cycle times at full engine revs			
Arms raise (full bucket)	Seconds	5.08	6.24
Shovel dump (full bucket)	Seconds	1.41	1.96
Arms lower (empty bucket)	Seconds	3.3	4.63
Total cycle	Seconds	9.79	12.83

CAB	In-cab noise level – 68dB(A).
STEERING	Hydraulic power steering.
BRAKES	Hydraulic power braking on all wheels. In-board mounted, oil immersed, multi-plate disc brakes. Parking brake, electro-hydraulic disc type operating on transmission output shaft.

SERVICE FILL CAPACITIES			
		427	437
Hydraulic system	litres	210	
Fuel tank	litres	290	270
DEF Tank	litres	40	

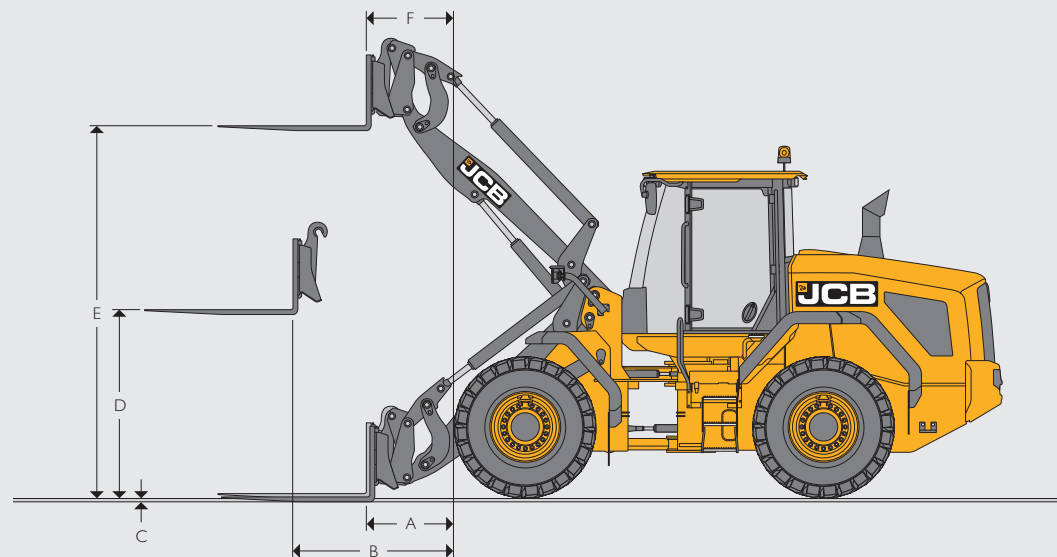

LOADER DIMENSIONS WITH FORKS

		427HT		427HT HL		427ZX	437HT		437HT HL		437 HT SHL	437ZX
		Parallel	Non parallel	Parallel	Non parallel	Parallel	Parallel	Non parallel	Parallel	Non parallel	Non parallel	Parallel
Fork carriage width	mm	1500	1500	1500	1500	1500	1500	1500	1500	1500	1500	1500
Length of tines	mm	1220	1220	1220	1220	1220	1220	1220	1220	1220	1220	1220
A Reach at ground level	mm	769	769	1238	1238	769	882	882	1518	1518	2079	882
B Reach at arms horizontal	mm	1546	1546	1895	1895	1546	1636	1636	2126	2126	2596	1636
C Top of tine above ground with arms down	mm	-52	-25	11	38	-52	8	16	3	11	-11	8
D Arms, horizontal height	mm	1906	1867	1906	1867	1906	1946	1936	1946	1936	1936	1946
E Arms, maximum height	mm	3718	3695	4148	4125	3718	3828	3818	4482	4472	5035	3828
F Reach at maximum height	mm	802	824	848	875	802	873	882	875	889	907	873
Tipping load straight	kg	10224	10980	7944	8399	8772	9089	9659	7655	8063	4315	9359
Tipping load full turn (40°)	kg	9587	9475	6852	7247	7550	7730	8218	6490	6839	5108	8025
Payload*	kg	7670	7580	5481	5798	6040	6184	6574	5192	5471	4086	6420
Attachment weight	kg	429	429	429	429	429	429	429	429	429	429	429
Operating weight (includes 75kg operator and full fuel and DEF tanks)	kg	13027	13027	13237	13237	13666	14438	14438	14857	14857	15307	14964

* At the centre of gravity distance 600mm. Based on 80% of FTTL as defined in ISO 14397-1:2007. Assume the fitment of Michelin 20.5R25 XHA2 (L3) and 5 speed transmission.

MATERIAL DENSITY

Material	Loose density	Fill factor
	kg/m ³	%
Snow (fresh)	200	110
Peat (dry)	400	100
Sugar beet	530	100
Coke (loose)	570	85
Barley	600	85
Petroleum coke	680	85
Wheat	730	85
Coal bituminous	765	100
Fertiliser (mixed)	1030	85
Coal anthracite	1046	100
Earth (dry) (loose)	1150	100
Nitrate fertiliser	1250	85
Sodium chloride (dry) (salt)	1300	85
Cement portland	1440	100
Limestone (crushed)	1530	100
Sand (dry)	1550	100
Asphalt	1600	100
Gravel (dry)	1650	85
Clay (wet)	1680	110
Sand (wet)	1890	110
Fire clay	2080	100
Copper (concentrate)	2300	85
Slate	2800	100
Magnetite	3204	100

BUCKET CAPACITIES – 427

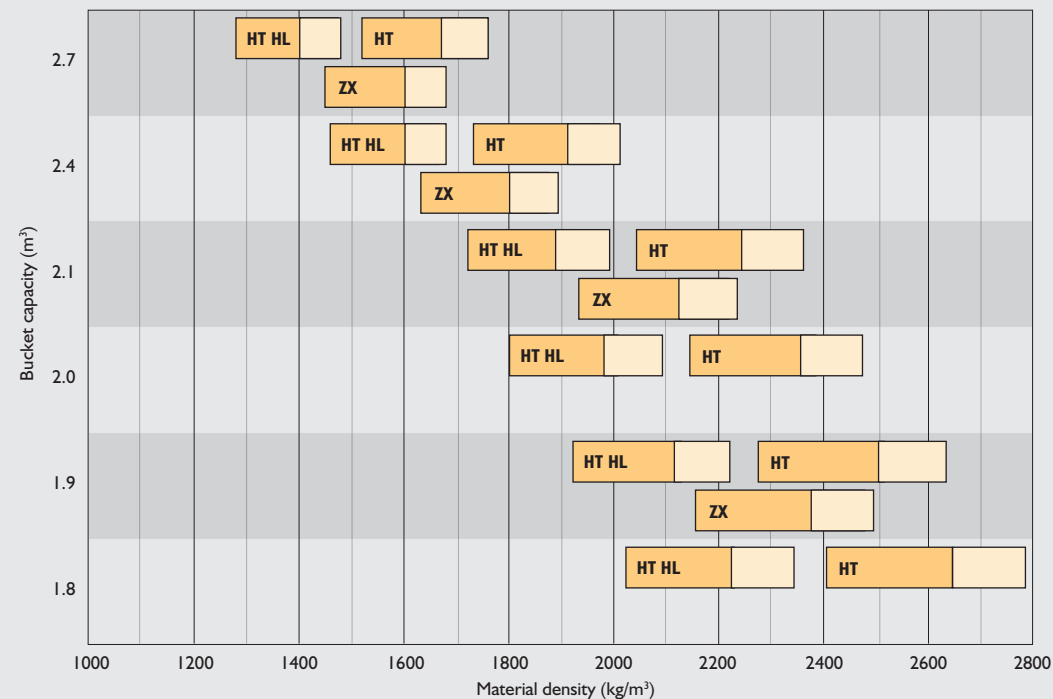

BUCKET CAPACITIES – 437

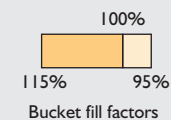
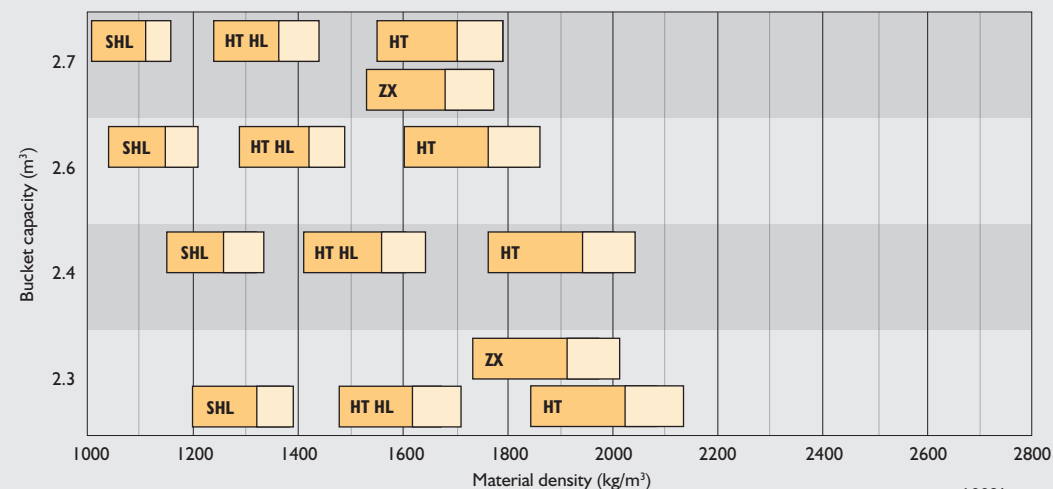

HT = Standard height arm HL = High Lift arm SHL = Super high lift arm ZX = Z bar

EQUIPMENT

SERVICE AND MAINTENANCE

5 year LiveLink telematics	•
Engine oil remote drain and fill	•
Grouped pressure test points	•
Lockable tool box	•
Lubrication points accessible from ground level	•

ENGINE

Air cleaner – cyclonic pre filter with engine fan scavenge system	•
Automatically reversing cooling fan	+
Crankcase breather oil trap	•
DEF fluid	•
Electrical opening rear bonnet	•
Epoxy coated radiator / coolers	+
Fixed mounted fan	•
Fuel filter	•
Fuel pre-filter with water trap	•
Hydraulically driven cooling fan	•
Manual override rear bonnet opening	•
-20° cold start	•
SCR engine emission control	•
Swing out fan	+
Waste gated turbo	•
Widecore cooling pack	•
Engine block heater (110V or 240V)	+
Auxiliary fuel tank + 110 litres (427 AGRI only)	+

ELECTRICAL

120 amp alternator	•
Amber rotating beacon	•
Electrical adjustable mirrors	•
Heated mirrors	•
External battery isolator	•
Fold down beacon arm	•
Green seat belt beacon	+
Halogen front and rear working lights	•
Hazard warning lights	•
Integrated rear view camera	+
LED front and rear working lights	+
LED 360 degree working lights	+
Number plate light kit	+
Parking lights	•
Radio wiring and speakers	•
Rear fog light	•
Reverse alarm and light	•
Smart reverse alarm and light	+
White noise reverse alarm and light	+
Work lights in rear grille	•
Bonnet operation alarm	•

ELECTRICAL (CONTINUED)

Blue LED reverse lights	+
-------------------------	---

DRIVE TRAIN

4 speed transmission	•
5 speed transmission with lock-up torque converter	+
6 speed transmission with lock-up torque converter (427 AGRI model only)	+
Epicyclical wheel hub reduction	•
Fixed front axle	•
Gear kick down on loader control lever	•
Indicator glass for transmission oil level	•
Limited slip differentials front and rear	+
Loader lever direction control	•
Neutral start	•
Standard differential	•
Standard differential with automatic locking -100% (front axle only)	+
Oscillating rear axle	•
Power-inch intelligent clutch cut off on footbrake (selectable)	•
Heavy duty front axle (427 only)	+
Sintered brake pads	+
Selectable automatic power shift	•
Speed limiter 20km/h	+
Steering column single lever shift control (direction and gear)	•
Transmission cooler bypass	+

BRAKE SYSTEM

Multi-plate wet disc brakes	•
Sintered brake pads	•
Dual circuit hydraulic power	•
Wheel speed braking	•
Parking disc brake on transmission output shaft	•
Electrical hydraulic park brake actuation	•
Accumulator back-up for electric park brake	•

OPERATOR STATION

Fully glazed cab	•
Front low windscreen guards	+
Air conditioning	•
Climate control	+
Single lever joystick	•
Multi-lever hydraulic controls	+
Proportional electro hydraulic auxiliary control	+
Electronically Adjustable hydraulic auxiliary flow rate	+
Air suspension cloth seat	•
Deluxe heated air suspension cloth seat	+
Super deluxe heated and cooled air suspension half leather seat	+
Front roller blind	•
Rear roller blind	+
Cab air intake filter	•

OPERATOR STATION (CONTINUED)

Carbon cab air intake filter	+
12V in cab power socket	•
2 x 12V in cab power socket	+
24V in cab power socket	+
Reversing camera (colour)	+
Fold away adjustable steering column	•
ROPS/FOPS safety structure	•
Interior light	•
Front primary display screen	•
Secondary A post display screen, rotary control menu interface	+
A post mounted membrane switches	•
Variable fan speed control on climatic control system	+
50 mm seat belt	•
3 inch seat belt	+
Fire extinguisher (UK only)	+
Two speed intermittent front windscreen wipe/wash and self-park	•
Single speed rear windscreen wipe/wash and self-park	•
3 speed heater/demisting	•
Variable speed heater	•
LH and RH sliding opening windows	•
Floor mat	•
Cup holder	•
Steering wheel spinner knob	•
Internal rear view mirror	•
Tinted cab glass	•
Multi-media port (USB and 3.5mm)	+
Operator stowage	•
Laminated windscreen	•
Heated rear screen	•
Loader control isolator	•
Horn	•
Adjustable armrest	•
Removable storage rubber mats	•
Convex mirror kit (1 on each side)	+
Adjustable seat mounted controls	•
Electronic adjustment of SRS (Smooth Ride System) cut in speed	+
Electronic adjustment of reverse fan interval	+

FRONT PRIMARY DISPLAY

Warning lights

Direction indicators	•
Master warning	•
High coolant temperature	•
Battery charging condition	•
Low fuel level	•
Engine oil pressure	•
Hazard lamps	•
Park brake state	•

EQUIPMENT (CONTINUED)

FRONT PRIMARY DISPLAY

Warning lights (continued)	
Road lights	•
Main beam lights	•
Rear fog lights	•
Engine pre-heat	•
Brake system pressure	•
Differential lock	•
Low steering pressure	•
Buzzer alerts	
Engine air filter blocked	•
Diesel exhaust fluid (DEF)	•
Torque reduction in case of malfunction	•
Amber warning lamp	•
Stop engine	•
Gauge display	
Engine speed	•
Coolant temperature	•
Fuel level	•
LCD screen display	
Current gear	•
Stop engine	•
Torque reduction in case of malfunction	•
Amber warning lamp	•
Diesel exhaust fluid (DEF)	•
Engine air filter blocked	•
Secondary steer system pressure	•
Torque lockup	•
Steer mode	•
Ground speed	•
Engine speed (numeric display)	•
Clock	•
Hydraulic state	•
Smoothride system (SRS)	+
Beacon	•
Front work lamps	•
Rear work lamps	•
Heated rear screen	•
Transmission sump temperature	•
Data screens	
DEF level	•
Hydraulic oil temperature	•
Torque convertor temperature	•
Volume of fuel remaining	•
Total fuel used (resettable)	•
Instantaneous fuel use	•
Average fuel use (resettable)	•
Current date	•
Machine hours	•

FRONT PRIMARY DISPLAY (CONTINUED)

Data screens (continued)	
Trip distance (resettable)	•
Hours to service	•
Daily checks	
Engine oil level	•
DEF level	•
RIGHT HAND SECONDARY DISPLAY (OPTIONAL)	
Clock	•
Climate control	•
Fan speed	•
In cab temperature set	•
Machine hours	•
Rear view camera with full-screen reverse mode	•
Fuel use	•
Adjustable smooth ride engagement speed	+
Adjustable reverse fan intervals	+
Adjustable auxiliary flow	+
Adjustable constant flow	+
Time and date	•
Hydraulic oil temperature	•
Transmission oil temperature	•
Machine settings screen	
Coolant temperature	•
Engine oil pressure	•
Air filter	•
Transmission sump temperature	•
Transmission torque convertor temperature	•
Hydraulic oil temperature	•
Park brake pressure	•
Battery voltage	•
Help display	•
On-screen handbook	•
HYDRAULIC SYSTEM	
Smoothride system (SRS)	+
Hydraulic quick hitch with in cab isolation	+
Auxiliary ARV kit	+
Auxiliary hydraulic service	+
Twin auxiliary hydraulic service	+
Twin piston pumps with priority steer	•
Emergency steer back-up	•
JCB biodegradable hydraulic oil	+
Electronic hydraulic isolation	•
Automatic boom kick-out. Detent	•
Automatic bucket positioner	•

HYDRAULIC SYSTEM (CONTINUED)

Front loader float	•
Constant auxiliary flow	•
Indicator glass for hydraulic oil level	•
Hydraulic oil cooler	•
EXTERNAL EQUIPMENT	
Front and rear fenders	•
Full rear fenders	+
Front adjustable mud flaps	•
Front wheel spray guards	•
Full tyre width coverage fenders	•
Rear object detection radar system with in cab display	+
Automatic greasing system	+
Grease gun and cartridge	+
One piece electrical opening bonnet	•
Mesh air intake screens	•
Flexible bottom step	•
Full width rear counterweight	•
Recovery hitch	•
Lifting / tie down lugs	•
Rear counterweight chevrons	+
Heavy duty rear counterweight (+312kg) only on 437	+
Rockinger rear towing hitch with hydraulic braking system (427 AGRI only)	+
PROTECTIVE EQUIPMENT	
Front cab screen guards	+
Wastemaster package: includes front and rear light guards, front screen guard, front and rear belly guards, rear light guards, widecore radiator, Wastemaster decal.	+
Heavy duty rear grille guard (available black or white)	+
Safety strut loader arm	•
Light guards	+
Front belly guard kits	+
Rear belly guard kits	+
Articulation joint safety strut	•
OTHER EQUIPMENT	
HT High Lift loader end (427 and 437)	+
HT Super High Lift loader end (437 only)	+
Parallel lift HT loader arms	+

STANDARD •

OPTIONAL +







ONE COMPANY, OVER 300 MACHINES.

Wheel Loader 427/437

- 427 – Operating weight: 13.1-16.5t Gross engine power: 133kW (179hp)
 Full turn tipping load: 8603kg Standard shovel capacity: 2.4m³
- 437 – Operating weight: 14.5-17.8t Gross engine power: 136kW (183hp)
 Full turn tipping load: 9605kg Standard shovel capacity: 2.7m³

Your nearest JCB dealer

JCB Sales Limited, Rokeceter, Staffordshire, United Kingdom ST14 5JP.

Tel: +44 (0)1889 590312 Email: salesinfo@jcb.com

Download the very latest information on this product range at: www.jcb.com

©2009 JCB Sales. All rights reserved. No part of this publication may be reproduced, stored in a retrieval system, or transmitted in any form or by any other means, electronic, mechanical, photocopying or otherwise, without prior permission from JCB Sales. All references in this publication to operating weights, sizes, capacities and other performance measurements are provided for guidance only and may vary dependant upon the exact specification of machine. They should not therefore be relied upon in relation to suitability for a particular application. Guidance and advice should always be sought from your JCB Dealer. JCB reserves the right to change specifications without notice. Illustrations and specifications shown may include optional equipment and accessories. The JCB logo is a registered trademark of J C Bamford Excavators Ltd.

