

NEW



LOADALL | 525-60 AGRI PLUS

Gross power: 55kW/74hp | Lift capacity: 2,500kg | Lift height: 6.0m



PRODUCTIVITY AND PERFORMANCE.

JCB HAS A PROVEN 35-YEAR TRACK RECORD OF DESIGNING AND MANUFACTURING WORLDBEATING AGRICULTURAL TELESCOPIC HANDLERS. THE NEW COMPACT 525-60 AGRI PLUS LOADALL IS THE LATEST IN THIS LONG LINE OF MACHINES BUILT FOR MAXIMUM PRODUCTIVITY ON THE FARM.

JCB's auto bucket control technology fitted to this machine provides rapid shaking of your bucket or muck fork with minimal joystick movement; this feature ejects material quickly and increases productivity.



A drivetrain for any application.

1 Our 2-speed hydrostatic transmission makes it easy for operators to achieve precise machine movements even in cramped spaces. The driveline works in parallel with the braking system too; a transmission dump on the foot brake offers superb multi-functioning and increased power during loading and rehandling.

2 Opt for our innovative vari-speed transmission which allows operators to preselect a preferred forward speed – a huge boon for users of hydraulic attachments like sweeper brushes or feeding buckets.

3 For ultimate traction and performance in soft, muddy conditions, we've fitted these telehandlers with 4WD and limited slip differential* as standard.

*Territory dependent



Loading performance.

9 This Loadall is great for loading and unloading at distance; there's a lift capacity of 750kg at 3.3m forward reach.

10 You can choose from seven quickhitch options including: JCB Q-fit, compact tool carrier, skid-steer, pin and cone, or Euro hitch.

11 A 6m lift height makes stacking straw bales safe and straightforward; lift capacity is 2500kg with the boom retracted, or 1500kg at full height.

12 For improved load retention and operator comfort (not to mention faster cycles and shorter journey times), we've equipped this telescopic handler with our optional innovative Smoothride System (SRS), which isolates the boom and load from chassis movements.

Added productivity.

13 This compact Loadall can be so much more than just a telehandler; choose from a range of rear tow hitch options, including trailer brakes, electrics, and rear auxiliary.

14 Hydraulic attachments can be operated with ease via single or double auxiliary services.

15 Transmission performance is key; that's why we've fitted a 30kph transmission giving superior tractive effort and pushing power as well as superb roading performance from field to farm.



EFFICIENT ENGINE DESIGN.

JCB LOADALLS HAVE ALWAYS BEEN FOCUSED ON MAKING THE MOST OF EVERY DROP OF FUEL. THE EFFICIENT NEW JCB DIESEL BY KOHLER ENGINE RANGE – AS FITTED TO THE 525-60 AGRI PLUS – TAKES THIS ETHOS TO THE NEXT LEVEL, OFFERING A WINNING COMBINATION OF PERFORMANCE AND FUEL SAVINGS.

You can rely on optimum engine performance in even the most demanding of applications with our wide core cooling package; its hydraulic reversing fan removes built-up debris from the cooling pack efficiently.

JCB Diesel by Kohler.

The 525-60 AGRI PLUS Loadall is equipped with a potent JCB Diesel by Kohler T4 Final (EPA compliant) engine that produces 300Nm of torque at just 1400rpm, and doesn't need costly DPF or DEF after-treatments.

Because it produces peak levels of torque at engine speeds as low as 1500-1600rpm, this engine can provide fuel-efficient matching of the transmission and hydraulics.

A variable speed fan automatically tailors its performance to suit the temperature of the engine, reducing overall fuel consumption.



QUALITY/RELIABILITY/DURABILITY.

SINCE THE VERY BEGINNING, JCB LOADALLS HAVE BEEN PRIZED FOR THEIR HIGH LEVELS OF BUILD QUALITY AND DURABILITY. THE NEW 525-60 AGRI PLUS IS NO DIFFERENT, BENEFITTING FROM ADVANCED PRODUCTION PROCESSES, INTENSIVE TESTING PROCEDURES AND PREMIUM COMPONENTRY.

Strength in depth.

1 The one-piece fully welded chassis maximises strength and minimises weight.

The boom is mounted low in the chassis, providing an extremely rigid structure.

2 Heavy-duty axle feet absorb the immense stresses generated during continuous heavy material rehandling.

3 For ultimate strength and durability, we've built in large boom overlaps of up to 0.7m.

4 We've fitted a tough inverted U-shaped boom pressing with fully welded closing plates. For extra strength, we've reduced the number of joints and stress points across our integrated boom nose and one-piece closing plate.

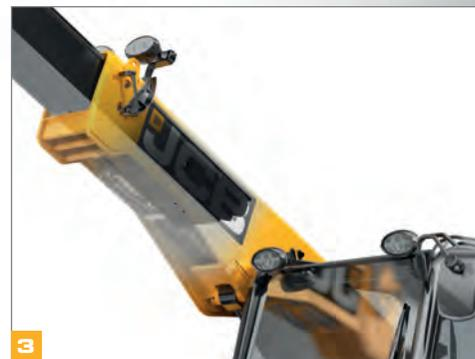

The hydraulic cylinders have friction-welded eye-ends for extra strength; all pivots use hardened pins.

Keyhole castings hold the tilt and extension rams to further improve overall structural integrity.

Quality, controlled.

5 Our stringent pre-production test programme included prolonged high stress loading of the chassis, boom and other key components, as well as repeated transmission use over thousands of cycles.

6 We use state-of-the-art manufacturing processes like robot machining, precision paint technology and innovative assembly techniques to achieve the very highest levels of quality.



COMFORT AND EASE OF USE.

IN ORDER FOR A TELEHANDLER TO OFFER ULTIMATE PRODUCTIVITY, IT NEEDS ITS OPERATOR TO BE COMFORTABLE AND FOCUSED. WITH THIS IN MIND, THE 525-60 AGRI PLUS IS EQUIPPED WITH AN OPERATOR AREA THAT'S ALL-DAY COMFY, ERGONOMIC, AND DESIGNED TO ACCOMMODATE INDIVIDUAL PREFERENCES.



Comfortably superior.

1 This telehandler has a large, spacious cab with a wide access door; inside, there's a radio speaker, a productivity-enhancing 7-speed heater fan, and plenty of underseat storage. The tilting steering column makes it easy to find a perfect driving position – all the more so with optional telescopic adjustment.

2 To help operators acclimatise fast, there are intuitive automotive ergonomics, all-new instruments and a hi-res TFT screen. Intuitively laid-out control switches are backlit for optimum night recognition.

Tinted cab glass is fitted as standard; 30% of the sun's energy is reflected, increasing operator comfort.



Intelligent controls.

3 Attachment-changing is quick and easy with our hydraulic auxiliary venting system, which dumps the hydraulic pressure in the auxiliary service line.

4 Controlling a JCB 525-60 AGRI PLUS is comfortable, precise and smooth: there are single lever electro servo controls with proportional auxiliaries, and there's a hand throttle option to complement our vari-speed transmission option.

5 JCB's proportional constant flow feature allows operators to programme different flow rates for different attachments.

We've made significant noise pollution reductions over outgoing models; the 525-60 AGRI PLUS is 76dB(A) quieter inside, and 103dB(A) quieter outside.



4

You can choose from a variety of seating options to suit all operators and applications. For the ultimate in operator comfort, the 525-60 Agri Plus is fitted with our deluxe cab as standard (with or without air con).



3



5



5

SAFETY AND SECURITY.

ON-FARM SAFETY IS OF PARAMOUNT IMPORTANCE, SO THE 525-60 AGRI PLUS HAS A WEALTH OF FEATURES DESIGNED TO PROTECT ITSELF, ITS OPERATORS AND ANY BYSTANDERS. A COMPREHENSIVE SECURITY PACKAGE CAN BE SELECTED.

Protecting people.

- 1 JCB's innovative Adaptive Load Control feature automatically prevents your machine from overturning forwards during heavy load handling.
- 2 To protect bystanders, we fit a reversing alarm as standard*, and there are also hose burst check valves (HBCVs) on the rams to guard against collapse in the event of a hose failure.
- 3 The cab is Roll Over Protection System (ROPS) and Falling Objects Protection System (FOPS) certified, so you can rest assured that operators are safe at all times.
- 4 A seat safety switch disables forward and reverse controls when your operator isn't seated.



Visibly better.

5 This Loadall is equipped with a full set of side and rear view mirrors for excellent visibility and full safety compliance.

6 All-round visibility is superb via the large roof screen, the opening rear window, the fold-back upper door, and the compact Kohler engine unit with its low-level sloping bonnet. In fact, rear visibility is class-leading thanks to our unique low profile rear chassis and boom.

7 Cab-mounted front and rear worklights provide great visibility. To make it even better (especially when loading at height in dark conditions), opt for our boom-mounted worklights

Safeguarding your investment.

8 JCB LiveLink's telematic GPS tracking provides invaluable real-time machine location data. Geofencing alerts help to ensure your machine remains on your farm.



COST OF OWNERSHIP.

WE BELIEVE THAT PROVIDING THE VERY BEST VALUE FOR MONEY SHOULDN'T BE RESTRICTED TO OFFERING A HIGHLY EFFICIENT ENGINE PACKAGE. THAT'S WHY THE 525-60 AGRI PLUS HAS A HUGE ARRAY OF EXTRA FEATURES DESIGNED TO KEEP YOUR COST OF OWNERSHIP TO A MINIMUM.

Saving you money.

Because the JCB Diesel by Kohler engine doesn't require exhaust after-treatment, you won't need to use costly heat-resistant lube oils.

To save you time and money, JCB's LiveLink telematics suite uses satellite technology to provide valuable real-time data on machine location, movements, health, usage and servicing requirements.

JCB Loadalls are heralded and sought after all around the world for their legendary productivity and build quality. By owning one, you'll benefit from the resulting high residual values.

Protected from downtime.

1 You can opt for a front screen guards for added protection from falling debris.

2 The side-mounted engine bonnet is safely recessed within the machine, providing increased protection from damage.

3 Steering rams are well out of harm's way, mounted high on the axle. This protects them from damage and minimises downtime.

4 By electrophoretically dipping the cab prior to the painting process, we ensure long-term corrosion protection.

To maintain strong residuals, Loadalls need to look good even after extensive use; that's why we use a powder coat paint process that's robust and resistant to stone chips.



SERVICEABILITY.

ANOTHER KEY TO ULTIMATE PRODUCTIVITY IS MINIMISED DOWNTIME. OUR ENTIRE LOADALL RANGE, INCLUDING THE 525-60 AGRI PLUS, IS THEREFORE DESIGNED TO KEEP SERVICING AND MAINTENANCE TO A MINIMUM. ROUTINE MAINTENANCE IS, OF COURSE, INEVITABLE, BUT EVEN WHEN IT'S DUE, YOU'LL FIND IT STRAIGHTFORWARD AND SPEEDY.

Easy access.

- 1 All of the daily checks and greasing can be done from ground level.
- 2 Fluid filters on these machines (engine oil, hydraulic oil and fuel) are within easy reach for fast, easy servicing. The air filter is easily accessible too, and a double-element construction simplifies cleaning.
- 3 With its gas-assisted cylinder, the bonnet is easy to open and close. The service bay within is large and wide enough to afford great access to three sides of the engine.
- 4 The diesel tank is easily accessed and filled from ground level. There's an integral pre-filter in the filler neck as well, offering protection from dirty fuel.

Keeping downtime down.

To ensure maximum uptime and productivity, service intervals on JCB Loadalls are lengthy.

- 5 Hydraulic hoses are intelligently routed through the boom for maximum protection.
- 6 Because the wear pads use a dry lubricant system, they only need servicing every 500 hours (compared to 250 hours on typical competitor machines).
- 7 Most Tier 4 Final engines use a Diesel Particulate Filter (DPF) or SCR, requiring additional DEF fluid level maintenance – with this JCB Diesel by Kohler engine just fuel up and go.

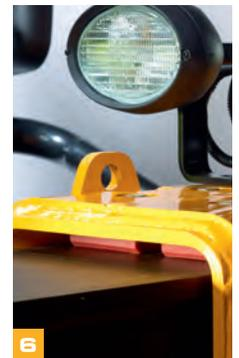

STYLE AND DESIGN.

THE LATEST JCB LOADALLS LIKE THE 525-60 AGRI PLUS HAS BEEN DESIGNED WITH VALUABLE INPUT FROM CUSTOMERS, AND IT'S VISIBLY DIFFERENT FROM ITS PREDECESSORS. THE CHANGES ARE MORE THAN SKIN-DEEP THOUGH; YOU'LL FIND A WEALTH OF INNOVATIVE FEATURES TO COPE WITH THE RIGOURS OF HARD WORK IN AGRICULTURAL APPLICATIONS.



Design that works harder.

- 1 JCB's new-look Loadall exterior isn't purely cosmetic; the cooling fan airflow is angled upwards, reducing time-consuming dust build-up.
- 2 The boom pivot point is low down; this helps to provide unrivalled visibility to the right hand rear wheel, often a blind spot on traditional telehandlers.
- 3 This machine shares key design elements with our larger Loadalls, including the distinctive and innovative side-mounted engine setup.
- 4 Our slimline outer boom section enables operators to see the front right-hand wheel with ease.
- 5 To keep this Loadall as narrow as possible, the cab door handle and hinges are fitted flush with the side of the machine.





LIVELINK, WORK SMARTER.

LIVELINK IS AN INNOVATIVE SOFTWARE SYSTEM THAT LETS YOU MANAGE JCB MACHINES REMOTELY – ONLINE, BY EMAIL OR BY MOBILE PHONE. ACCESS EVERYTHING FROM MACHINE ALERTS TO FUEL REPORTS AND HISTORY INFORMATION, WITH ALL DATA STORED AT A SECURE CENTRE.

Productivity and cost benefits

By providing information like idle time monitoring and machine fuel consumption, JCB Livelink helps reduce your fuel usage, saving money and improving productivity. Machine location information can help improve efficiency and perhaps even reduce insurance costs.

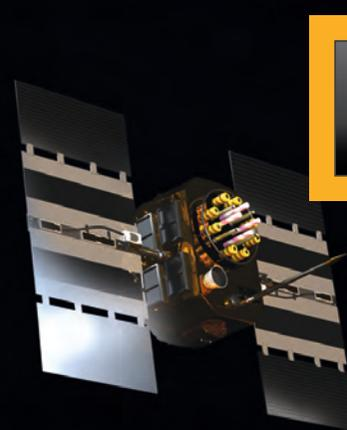

Maintenance benefits

Manage machine maintenance easily – accurate hours monitoring and service alerts improve maintenance planning, while real-time location data helps you manage your fleet. Critical machine alerts and maintenance history records are also available.



Security benefits

Livelink's real-time geofencing alerts tell you when machines move out of predetermined zones, and real-time curfew alerts inform you of unauthorised usage. Further benefits include real-time location information.



VALUE ADDED.

JCB'S WORLDWIDE CUSTOMER SUPPORT IS FIRST CLASS. WHATEVER YOU NEED AND WHEREVER YOU ARE, WE'LL BE AVAILABLE QUICKLY AND EFFICIENTLY TO HELP MAKE SURE YOUR MACHINERY IS PERFORMING TO ITS FULL POTENTIAL.



1

1 Our Technical Support Service provides instant access to factory expertise, day or night, while our Finance and Insurance teams are always on hand to provide fast, flexible, competitive quotes.

2 The global network of JCB Parts Centres is another model of efficiency; with 16 regional bases, we can deliver around 95% of all parts anywhere in the world within 24 hours. Our genuine JCB parts are designed to work in perfect harmony with your machine for optimum performance and productivity.



2

3 JCB Assetcare offers comprehensive extended warranties and service agreements, as well as service-only or repair and maintenance contracts. Irrespective of what you opt for, our maintenance teams around the world charge competitive labour rates, and offer non-obligation quotations as well as fast, efficient insurance repair work.



3

Note: JCB LIVELINK and JCB ASSETCARE may not be available in your region, so please check with your local dealer.

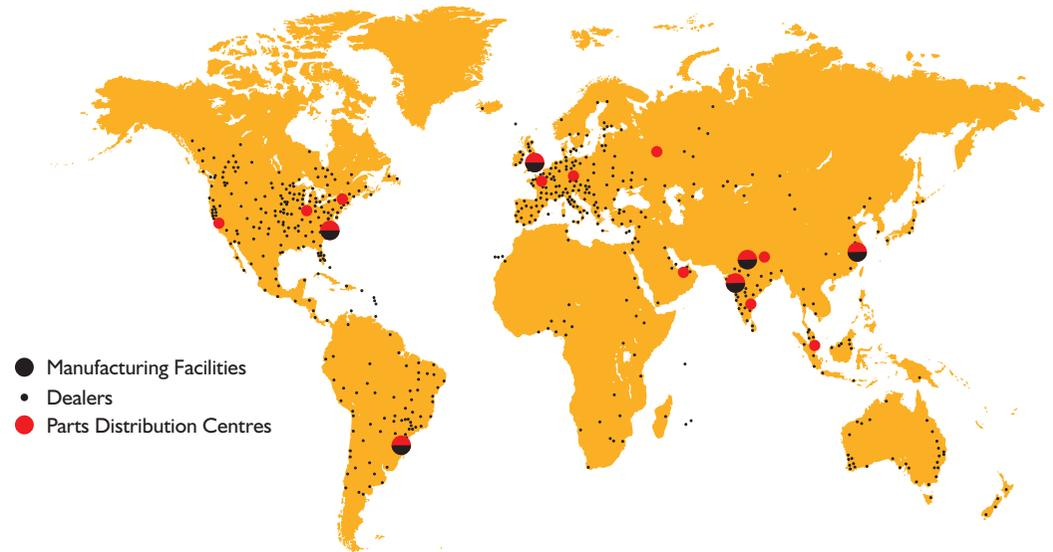

- Manufacturing Facilities
- Dealers
- Parts Distribution Centres

STATIC DIMENSIONS

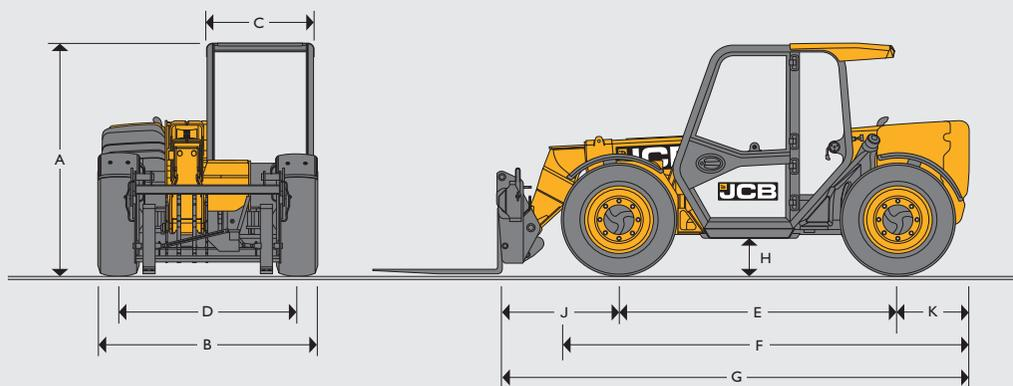

		525-60 Agri Plus
A	Overall height	m 1.97
B	Overall width (over tyres)	m 1.84
C	Inside width of cab	m 0.88
D	Front track	m 1.52
E	Wheelbase	m 2.39
F	Overall length to front tyres	m 3.48
G	Overall length to front carriage	m 4
H	Ground clearance	m 0.33
J	Front wheel centre to carriage	m 1.02
K	Rear wheel centre to rear face	m 0.6
	Outside turn radius (over tyres) 4WS	m 3.4
	Carriage roll back angle	degrees 11
	Carriage dump angle	degrees 114
	Weight	kg 5580
	Tyres	industrial traction 12.5/80x18

LIFT PERFORMANCE

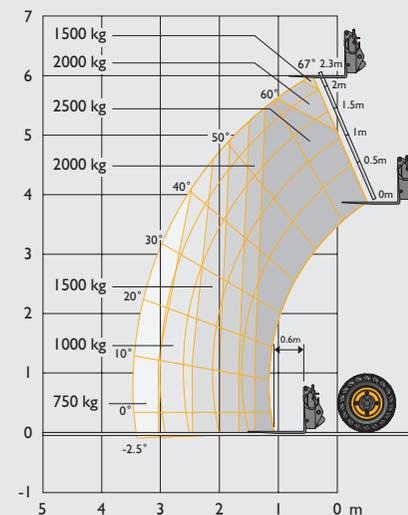

		525-60 Agri Plus
Maximum lift capacity	kg	2500
Lift capacity to full height	kg	1500
Lift capacity at full reach	kg	750
Lift height	m	6
Reach at maximum lift height	m	-0.25
Maximum forward reach (to front of carriage)	m	3.3
Reach with 1.2 tonne load	m	2.58

Complies with stability test AS 1418.19

ENGINE

Latest Tier 4 Final technology and advanced design provides low fuel consumption, reduced noise, high torque and power output, total reliability and minimal maintenance. Two-stage, dry type air filter with primary and safety elements.

		525-60 Agri Plus
Manufacturer		JCB DIESEL BY KOHLER
Displacement	ltr	2.5
No. of cylinders		4
Bore size	mm	88
Stroke	mm	102
Aspiration		Turbocharged cooled
Power rating		
Power @ 2200rpm	kW (hp)	55 (74)
Torque rating		
Torque @ 1500rpm	Nm	300

HYDRAULICS		
		525-60 Agri Plus
Operating system pressure	bar	260
Flow at system pressure @ 2200rpm	ltr/min	90
Hydraulic cycle times		
Boom raise		5.7
Boom lower		5.5
Boom extend		5.5
Retract		3.3
Bucket dump		1.9
Bucket crowd		2.2

TRANSMISSION			
Closed loop variable displacement pump with a continuously variable hydrostatic drive. Comprising of a hydraulic motor and control unit. Permanent 4 wheel drive.			
		525-60 Agri Plus	
		Forward	Reverse
Low range	kph	12	12
Hi-range	kph	30	30

ELECTRICS		
		525-60 Agri Plus
System voltage	Volt	12
Alternator output	Amp hour	100
Battery capacity	Amp hour	120

AXLES	
Front and rear drive axles: epicyclic hub reduction drive/steer axles with torque proportioning differentials.	

BRAKES	
Service brakes: Hydraulically operated self-adjusting, oil-immersed in-board multi-disc type mounted on front axle.	
Parking brake: SAHR Handbrake self adjusting, oil immersed in-board multi disc type mounted on front axle operated by in-cab switch.	

SERVICE FILL CAPACITIES		
		525-60 Agri Plus
Hydraulic system	litres	65
Fuel tank	litres	75

BOOM AND CARRIAGE	
Boom is manufactured from high tensile steel. Low maintenance, hard wearing pads. Carriage options include JCB Q-Fit, JCB compact toolcarrier, Skid-Steer, Eurohitch, Pin and Cone available.	

NOISE AND VIBRATION			
		Uncertainty	Measurement conditions
Noise at the operator station (LpA)	76 dB	+/- 1 dB	Determined in accordance with the test method defined in EN 12053
Noise emission from the machine (LWA)	103 dB	+/- 1 dB	Guaranteed equivalent sound power (external noise) determined in accordance with the dynamic test conditions defined in 2000/14/EC
Whole body vibration (m/s ²)	0.37	0.18	ISO 2631-1:1997 normalised to an 8h reference period and based upon a test cycle defined in SAE J1166
Hand-arm vibration (m/s ²)	<2.5	N/A	ISO 5349-2:2001 dynamic test conditions

STANDARD/OPTIONAL EQUIPMENT		
	AGRI PLUS	AGRI PLUS
ENGINE AND COOLING		
74hp JCB Diesel by Kohler Engine	●	
Widecore cooling pack & Reverse fan	●	
Auto reversing fan	○	
TRANSMISSION / AXLES		
2 speed transmission 20kph (TÜV)	○	
2 speed transmission 30kph	●	
Forward / reverse controls on joystick	●	
Column mounted transmission selector	●	
Limited slip front differential	○	
Varispeed transmission	○	
HYDRAULICS		
Servo controls	●	
Flow sharing hydraulics	●	
Proportional boom and auxiliary controls	●	
Adjustable constant flow hydraulics	●	
90 l/min variable displacement piston pump	●	
Auxiliary venting	●	
Hose burst check valves	●	
JCB Adaptive load control	●	
JCB Smoothride system	○	
End damped boom ram	●	
STEERING		
3 steer modes	●	
Manual selectable steer modes	●	
Electric selectable steer modes	○	
CAB		
ROPS/FOPS safety structure*	●	
Laminated screen	●	
Fully adjustable mechanical seat	●	
Air suspension seat	○	
Interior light	●	
Tilt and telescopic steering column	●	
2 speed front and rear wash/wipe	●	
Roof wiper	●	
Radio speaker installation	●	
12V power socket	●	
7-speed heater fan	●	
Air conditioning	○	
Front and roof screen blinds	●	
Single lever joystick controls	●	
Loader control isolator	●	
External rear view mirrors	●	
Fire extinguisher	○	
Front screen guard	○	
ELECTRICAL		
Road lights front and rear	●	
Reverse lights	●	
Battery isolator	●	
Rotating beacon	○	
Front and rear worklights	○	
Boom worklights	○	
Liveline telematics	○	
Key immobiliser	○	
Key pad immobiliser	○	
Reverse alarm	●	
Towing facility with trailer lighting	○	

● STANDARD

○ OPTIONAL

* Conforms to ROPS ISO 3471 and FOPS ISO 3449.



ONE COMPANY, OVER 300 MACHINES.

Your nearest JCB dealer

LOADALL 525-60 AGRI PLUS

Gross power: 55kW/74hp Lift capacity: 2,500kg Lift height: 6.0m

JCB Sales Limited, Rokester, Staffordshire, United Kingdom ST14 5JP.

Tel: +44 (0)1889 590312 Email: salesinfo@jcb.com

Download the very latest information on this product range at: www.jcb.com

©2009 JCB Sales. All rights reserved. No part of this publication may be reproduced, stored in a retrieval system, or transmitted in any form or by any other means, electronic, mechanical, photocopying or otherwise, without prior permission from JCB Sales. All references in this publication to operating weights, sizes, capacities and other performance measurements are provided for guidance only and may vary dependant upon the exact specification of machine. They should not therefore be relied upon in relation to suitability for a particular application. Guidance and advice should always be sought from your JCB Dealer. JCB reserves the right to change specifications without notice. Illustrations and specifications shown may include optional equipment and accessories. All images are correct at time of print. The JCB logo is a registered trademark of J.C. Bamford Excavators Ltd.

