



FASTRAC | 4000 SERIES

Rated power: 4220 217hp (162kW)



IT'S TIME FOR A NEW GENERATION.

A NEW GENERATION FASTRAC. RAISING PERFORMANCE AND PRODUCTIVITY LEVELS TO NEW HEIGHTS WITH SEAMLESS CONTROL, FASTER OPERATING SPEEDS, MULTIPLE IMPLEMENT MOUNTINGS AND FASTRAC'S UNRIVALLED SELF-LEVELLING SUSPENSION ALL ROUND. IT'S ALL THE TRACTOR YOU WILL EVER NEED.

Experience counts.

1 All-new Fastrac 4000 Series draws on more than 25 years of experience and expertise in design, development and manufacture of the world's most versatile and comfortable tractor.

2 A design that builds on core Fastrac features and capabilities – multiple implement mounting points for the ultimate in tractor utilisation, fast field and road speeds with more sophisticated all-round suspension and braking for stability, safety and comfort.



Designed from the ground up, the 4000 Series combines the core Fastrac principles with industry-leading components.



1



2



Better in every way.

3 A stable and highly manoeuvrable platform for in-crop applications – all the more so with optional tighter turning four wheel steer and new RapidSteer for quicker, more efficient headland turns.

4 The new CommandPlus cab – all the space, visibility, control features and comfort you could ever want.

5 More power and better traction from larger tyres make the new Fastrac 4000 Series a top performer in the field.

Fastrac 4000 Series

Model	Rated power (97-68 EC)	Max. power (97-68 EC)
4220	217hp	235hp

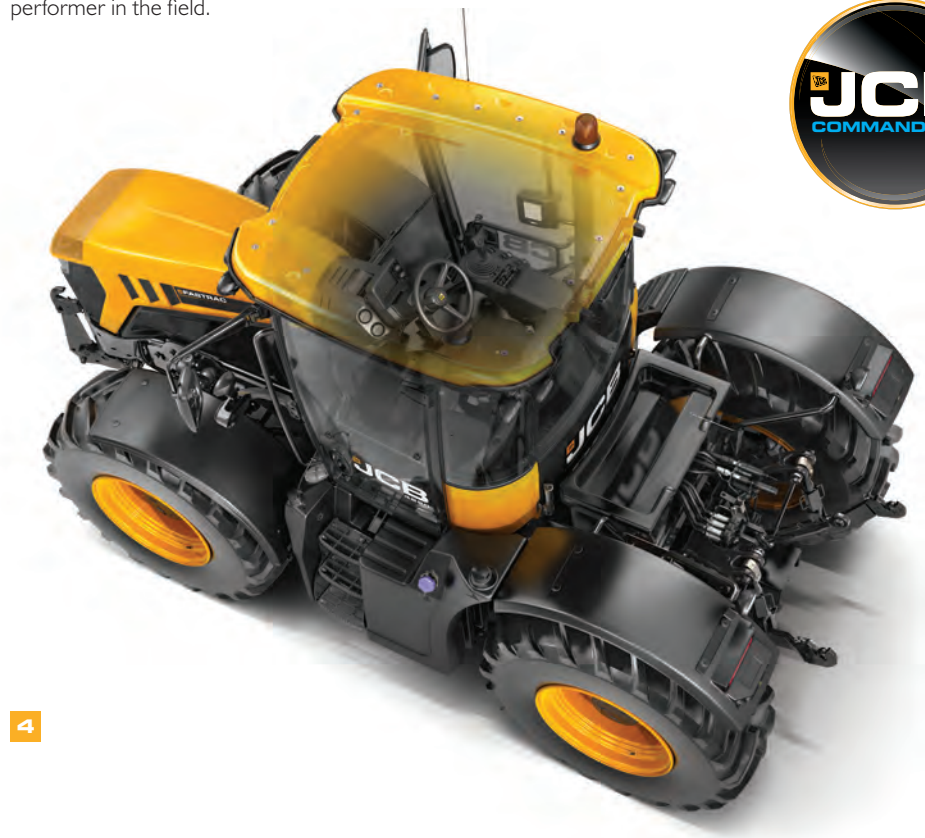

4

Self-levelling suspension – front and rear – keeps the boom and tanks at a constant height.



3



5



COST EFFICIENT PRODUCTIVITY.

THE ALL-NEW FASTRAC 4000 SERIES PACKS SOME GREAT INDIVIDUAL FEATURES. BUT WHAT REALLY SETS IT APART IS THE WAY THEY COME TOGETHER TO RAISE THE TRACTOR'S PERFORMANCE AND PRODUCTIVITY AS A WHOLE.

How will you use yours?

1 The Fastrac 4000 Series works so well in so many roles that it will always be the tractor of choice – for grassland, arable, haulage and livestock operations. Look no further for the best return on investment.

2 Compare Fastrac performance with conventional tractors. Faster in-field speeds, greater load carrying capacity, quicker headland turns and faster transfer speeds can save several working days a year. How's that for cost-effective productivity?

3 Three-point headland turns are a thing of the past with four-wheel steering; use the sub-10m turning circle to sweep round and get back to work quicker – it's 40% faster and no interruption of drive reduces wear and tear.



Extra capacity, more output.

4 Use the rear deck to boost productivity – carrying an extra 2.25m³ of seed can reduce drill refilling stops to just once a day. Put the drill hopper up front for ultimate capacity and 50:50 weight distribution, with scope to use a wider power harrow-seed drill combination to further boost productivity.

5 No need to buy a bigger fertiliser spreader – use the Fastrac's 4-tonne capacity rear deck to carry another 2.5 tonnes of fertiliser. This gives you better weight distribution and the ability to cover an extra 10ha with every fill. Add faster return-to-base fill-up journeys, and Fastrac will fit in an extra hour's productive work every day.

6 Gain two-thirds more spray tank capacity by ditching the 1500-litre linkage sprayer for a 2500-litre demount. Or go large with a front-linkage tank for up to 4000-litre capacity!



POWERFUL CONTROL.

MORE POWER! DRIVERS OF THE MOST COMPACT TRACTOR IN THE FASTRAC RANGE NOW HAVE UP TO 235HP AND 42% MORE TORQUE AT THEIR COMMAND. THAT'S SERIOUS PERFORMANCE BRINGING A SERIOUS INCREASE IN PRODUCTIVITY.

The 4000 driveline produces plenty of grunt at low revs, maximising performance and efficiency.



Power to perform.

- 1 Proven fuel efficiency and a generous supply of power up to 235hp (175kW) and torque up to 950Nm come from a new 6.6-litre, six-cylinder engine.
- 2 SCR emissions system is fuel-efficient technology proven on other models in the Fastrac range.
- 3 Active Traction manipulates torque output to keep the tyres gripping for maximum pulling power with minimum wear.



Activ Traction

Efficient power delivery.

- 4 New CVT transmission ensures optimum use of power and torque, with seamless acceleration and power delivery, ideal speeds for every situation, and ultra-fine speed control for top-quality work with all implements.
- 5 Different transmission and engine control strategies are easily engaged using the Fastrac's touch screen controller – prioritise power and productivity, fuel economy, fixed engine/PTO speed, fuel-efficient road travel.
- 6 Fast on the road and in the field with low engine revs: 60kph at just 1600rpm or drive for maximum fuel economy at 50kph with just 1400rpm on the clock (tyre dependent).



SUSPENSION REDEFINED.

MORE THAN 25 YEARS OF FASTRAC ENGINEERING IS CONCENTRATED INTO THE NEW SELF-LEVELLING SUSPENSION SYSTEM TO CREATE THE SMOOTHEST RIDING TRACTOR YOU CAN OWN. FAST IN THE FIELD, FAST ON THE ROAD.

Active support.

- 1 Fastrac's unique self-levelling rear axle suspension is now matched by a new hydraulic front suspension system that maintains correct ride height wherever the implement is mounted.
- 2 Active suspension quickly responds to coupling a linkage-mounted implement or de-mount sprayer or spreader, restoring ride height, wheel travel and stability with a stiffer spring rate to support the extra weight.
- 3 As spray tank or seed hopper empties, or a plough or cultivator is lowered to the ground, the suspension compensates again to keep tractor, driver and implement on the level.



With GPS autosteer and HTA enabled you can increase accuracy and reduce fatigue.

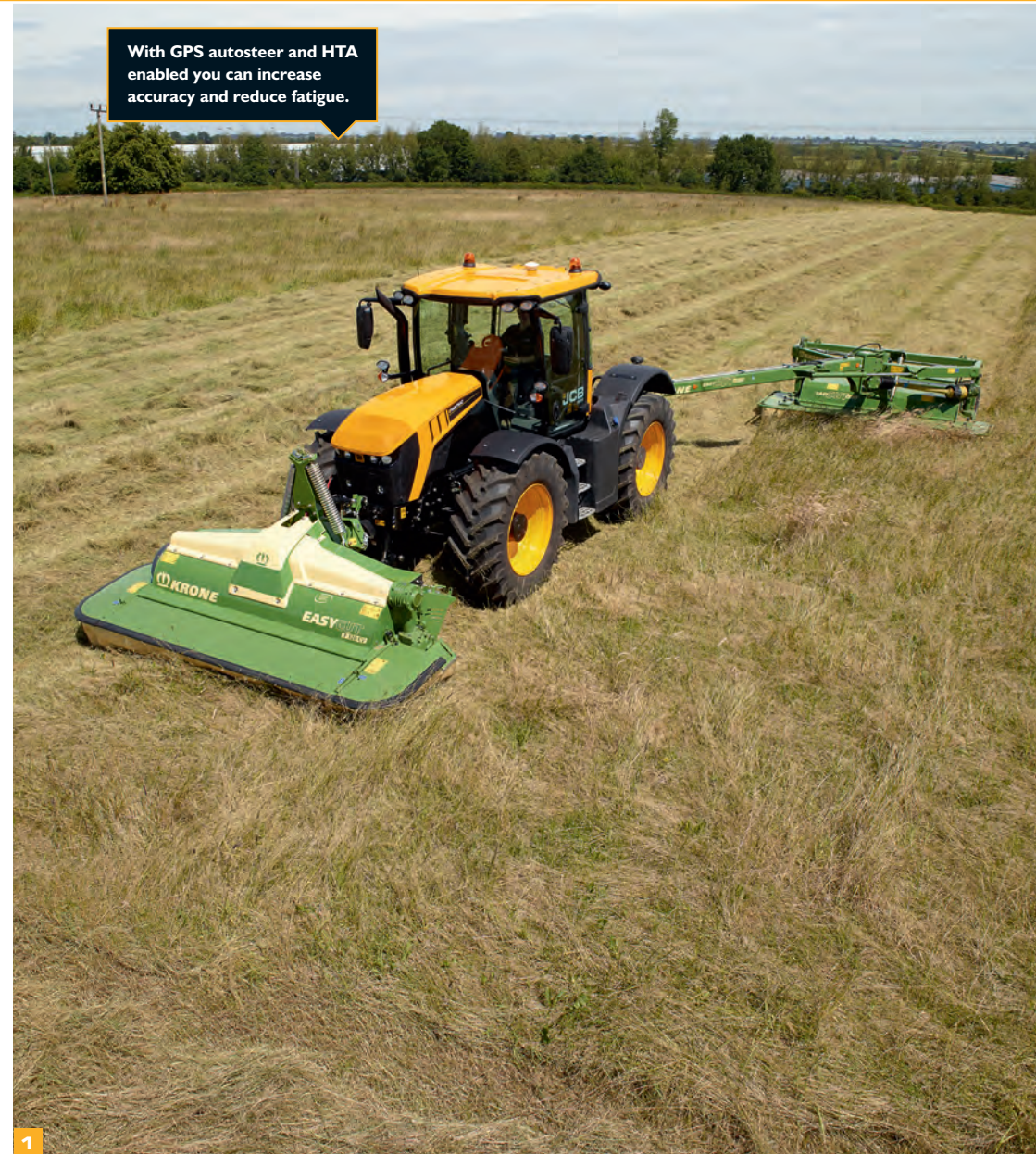

Advanced options.

- 4 Optional advanced double-acting suspension-features larger suspension components for increased performance with adaptive pressure and damping control, that takes stability, control, ride comfort and handling to levels never before seen in an agricultural vehicle. It also allows the tractor to 'squat' and slide beneath a demount sprayer, spreader or bulk hopper for quicker and easier switching between different tasks.
- 5 Smooth-riding chassis provides a stable platform for spraying and spreading with consistent working heights and high operating speeds.
- 6 Mounted implements are cushioned from shocks and jolts by axle suspension front and rear, not just by hydraulic linkage damping.
- 7 The JCB Fastrac 4000 has more safety features than any other tractor in its class.



Unique side-to-side active levelling promotes maximum stability, driver confidence and productivity, particularly in difficult terrain.



MULTI-TASKING CAPABILITY.

HERE, THERE, EVERYWHERE. THE MULTI-TASKING FASTRAC 4000 SERIES HAS FIVE LOCATIONS FOR IMPLEMENTS – DRAWBAR, REAR LINKAGE, FRONT LINKAGE, FRONT CHASSIS, REAR DECK. NO WONDER IT'S SO VERSATILE AND PRODUCTIVE.

Versatility is standard.

1 It's the Swiss Army knife of tractors in a small but powerful package. Make use of five implement positions, including the chassis for a front loader, to do more operations in one go.

2 Maximum Permissible Vehicle Weight is up to 13 or 14 tonnes (depending on territory and configuration) with the ability to mount up to 4 tonnes on the rear deck – so the Fastrac 4000 Series can carry loads more – increase productivity with bigger implements and fewer refill stops.



High performance.

3 New flow-on-demand closed centre hydraulics system ensures there's plenty of oil for every situation delivered economically. An axial piston pump provides up to 148 litres per minute for auxiliary services, while a separate gear pump ensures a dedicated supply to the steering system.

4 New three point linkage system features up to 8,000kg lift capacity with new geometry ensuring plenty of muscle and lift for large implements. Front linkage capacity is now up to 3,500kg.

5 Specify the 4000 Series with a range of drawbar and rear deck options to suit your operation. Weight blocks, storage trays, spider frames and more can be fitted to the rear deck.



3



5



5



4

WORKING CLASS.

THE NEW COMMAND PLUS CAB IS THE LARGEST ON THE MARKET WITH BEST-IN-CLASS COMFORT, VISIBILITY AND ERGONOMICS. AS SOON AS YOU STEP IN YOU'LL SEE THE DIFFERENCE.

1 Space, comfort, practicality – three words that sum up the Fastrac's new Command Plus cab. All-round visibility is great, all controls are placed easily to hand, and there's a full-size instructor's seat, so everyone rides safely in comfort.

2 Leather trim is the ultimate luxury for a comfortable and supportive driver's seat that can rotate fully 50 degrees right and 20 degrees left.

3 Attaching the slim instrument casing to the steering column means it remains visible however the wheel can be adjusted for reach and angle without impeding forward visibility.

4 Forward-raked 'A' pillars make the doorways bigger and increase interior spaciousness, while the near-vertical windscreen reduces heat absorption on a sunny day.

New instrument panel positioned directly ahead of the driver presents all essential vehicle information and warnings on a bright, high-definition display that needs only a glance to keep an eye on speeds.

Fully adjustable steering wheel and column, and ideally located pedals, provide the perfect driving position.



There is audio input compatibility with the sound system, or specify a Bluetooth radio.

Everything to hand.

6 Deep door glass and rear three quarter opening windows ensure good forward, side and over-the-shoulder visibility. The 220 degree wiper provides maximum visibility in all weathers.

6 Seat-mounted console houses the most frequently used control switches and dials with a generously padded armrest built in.

7 Switches used less often are arranged logically on the right-hand cab pillar – out of the way but within easy reach when needed.

8 Optional electric cool box stores food and drinks. A folding moulded seat back forms a handy flat surface that's ideal for lunch breaks and making notes for field records.

9 Climate control air conditioning keeps the temperature comfortable and quickly de-mists the windows on early mornings. Opening rear three-quarter windows add natural ventilation and a fixed roof window option floods the cab with light.

10 Extra lamps in the bonnet and optional LED work lights illuminate the area around the tractor as if it were daytime!

11 External LED work light remains on to give you time to exit the cab safely and proceed on your journey home.



FINGERTIP TECHNOLOGY.

EASILY ACCESSIBLE AND EASY TO USE TECHNOLOGY THAT LIFTS PRODUCTIVITY AND MAKES THE OPERATOR'S JOB EASIER AND MORE SATISFYING.

High-tech drivetrain.

1 An integrated engine and transmission partnership automatically balanced to achieve the desired performance and exploiting high power and torque outputs at fuel-efficient engine speeds.

2 Fast on the road and in the field with low engine revs: 60kph at just 1600rpm or drive for maximum fuel economy at 50kph with just 1400rpm on the clock (tyre dependent).

3 GPS-ready infrastructure makes guidance a cost-effective option for accurate bout matching, maximum output, minimum inputs and reduced operator fatigue.

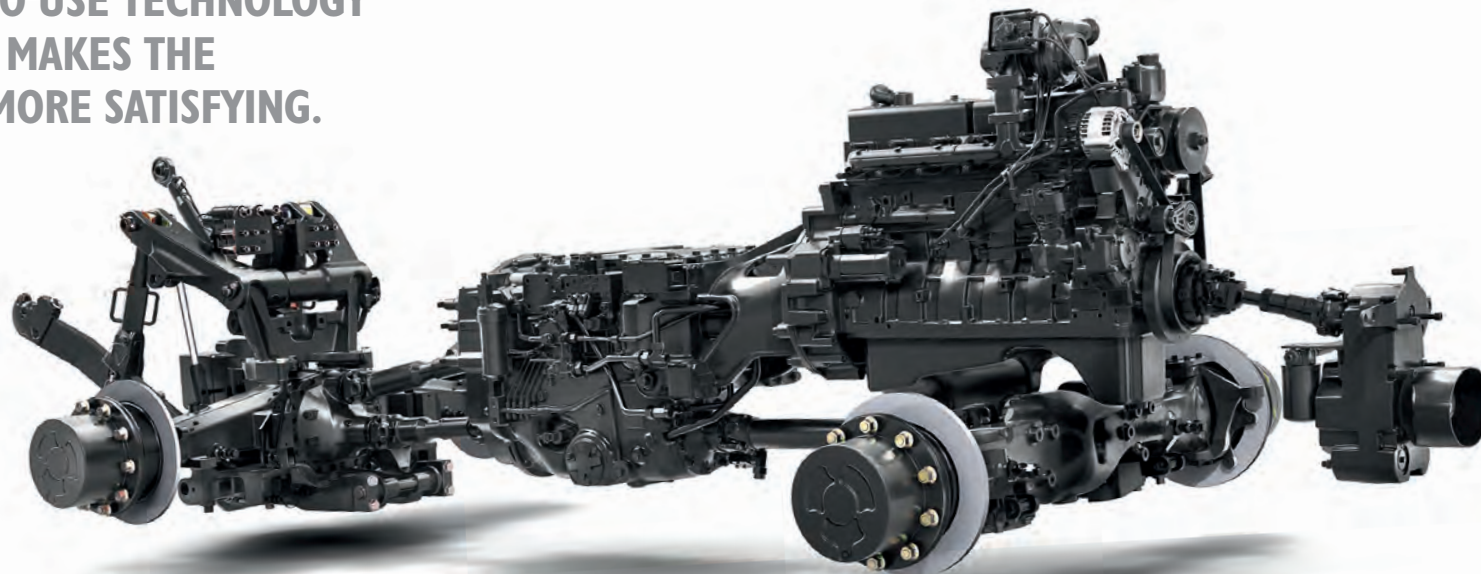

1



2



3



Fingertip control.

4 Colour touch screen terminal is standard equipment, handling the key tractor functions in the most intuitive and clearest way.

Headland Turn Assist (HTA) is easily programmed using the touch screen – set up and store control sequences for five different implements, with up to 15 steps in each, for simpler headland turns.

5 New RapidSteer option reduces arm twirling for headland turns and loader work – to just two turns lock-to-lock.

6 Shed light on the Fastrac and its surroundings with the optional LED package and work lamps – up to 18 lights in all for near-daylight visibility when working at night.



SWIFT AND AGILE.

UNIQUE FOUR-WHEEL STEERING HELPS FASTRAC 4000 SERIES RUN RINGS ROUND CONVENTIONAL TRACTORS. NEW GENERATION FASTRAC IS MORE AGILE AND MANOEUVRABLE THAN EVER BEFORE.

Save time.

1 The new compact chassis is narrower where it counts – so turns are tighter than ever. Tyre sizes now include 600/70R30 and 540/65R34 to complement the tractor's 50:50 weight distribution.

2 New Rapid Steer option makes headland turns quicker, easier and less tiring for the operator.

3 Optional four-wheel-steering reduces the tractor's turning circle to less than 10m (tyre dependent). A three position switch allows the operator to quickly switch between 2WS, 4WS and a fully user programmable setting.

4 Choose fully integrated high definition GPS guidance for increased field work precision, greater output from optimum implement width, continued working at night and in low-visibility conditions, and improved operator welfare from reduced fatigue.



Choose from 5 steer modes for maximum productivity with minimum crop damage.

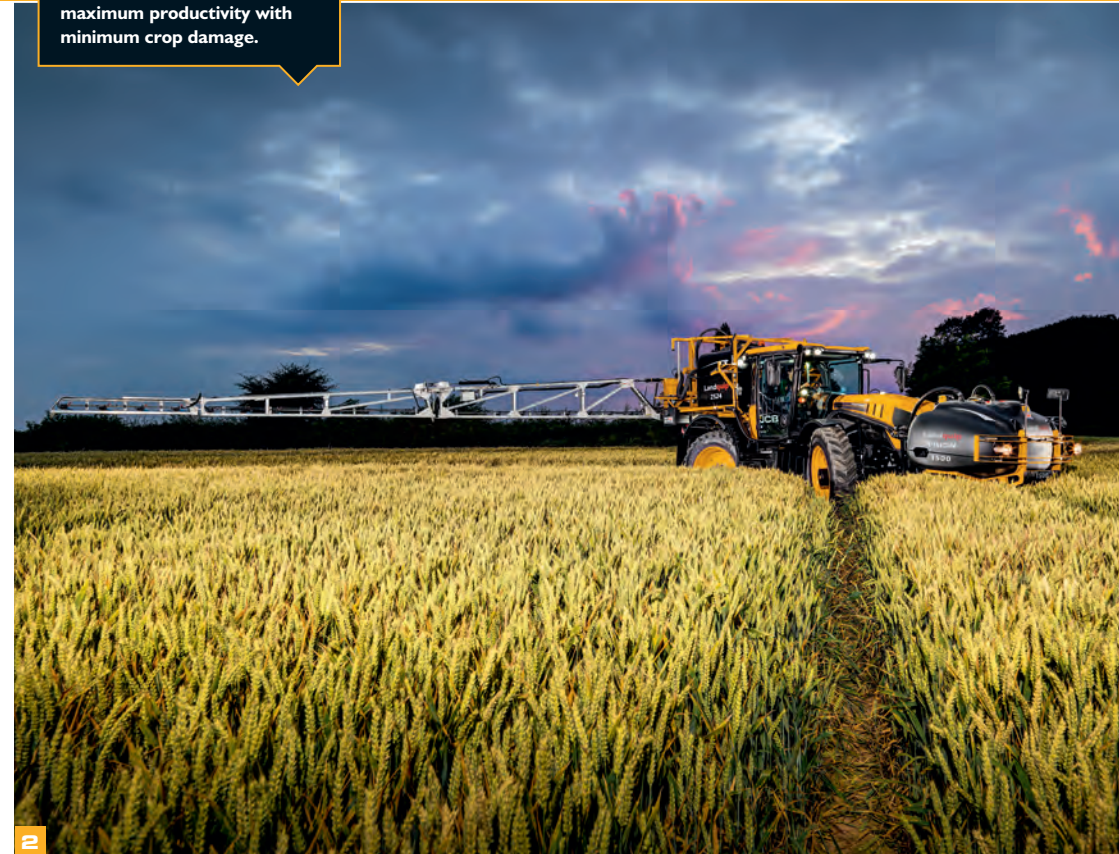

Five instantly selectable steering modes.

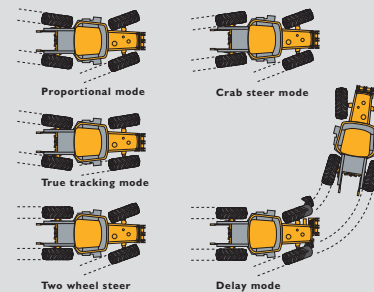

SAFE AND SECURE.

HIGH-SPEED ROAD TRAVEL BRINGS WELCOME BENEFITS BUT ALSO RESPONSIBILITIES. THAT'S WHY EVERY JCB FASTRAC HAS A UNIQUE COMBINATION OF SAFETY FEATURES.

Safety first.

1 High performance disc brakes all round provide maximum stopping power – they can consistently bring a Fastrac and its load to a halt up to 15% quicker than conventional tractors.

2 Every Fastrac is available with ABS for skid-free controllable tractor and implement/trailer braking in all conditions. It even works on tricky off-road surfaces.

3 Completely new stiffer chassis and suspension with anti-rollbars front and rear bring superior handling and stability during high-speed travel.

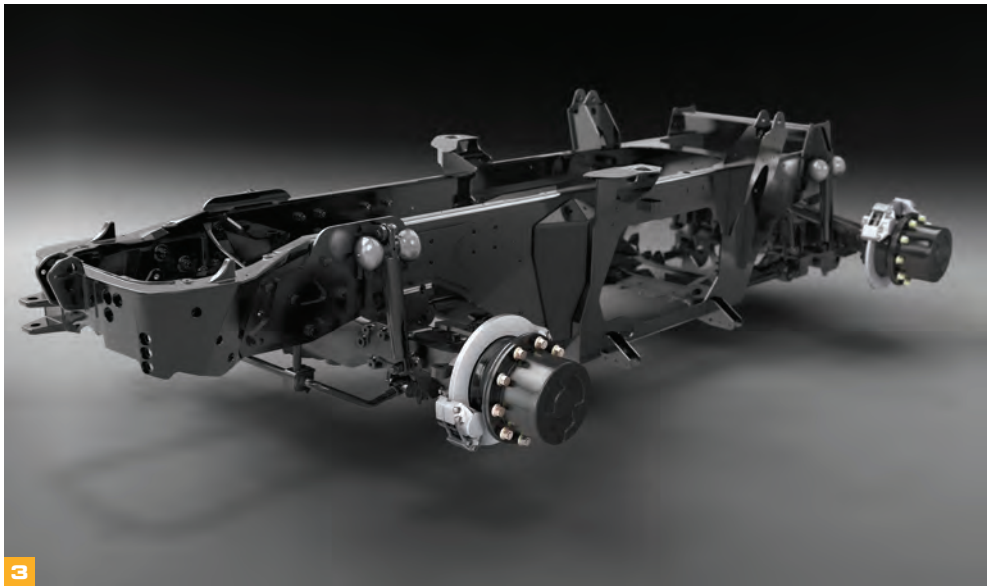

DESIGNED TO PASS ANY TEST.

HOT WEATHER, COLD WEATHER, RAIN, SNOW, FOG, DUST AND MUD. THE NEW FASTRAC 8000 SERIES HAS BEEN TESTED TO WORK IN EVERY CONDITION. SO WHEREVER AND WHENEVER YOU WORK, YOU WON'T NOTICE A DIFFERENCE IN PERFORMANCE.

Tried, tested, trusted.

1 From the fields of Europe to the snowy landscapes of Scandinavia; and from the chill of the Arctic to the searing heat of Africa we test our Fastrac tractors to the extreme.

2 Every nut and bolt, every moulding and fabrication, every sub-assembly and major component must work to the standard expected of every JCB machine.

3 Durability is designed-in and built-in; we change, improve and refine in response to customer feedback and to meet the high standards we set ourselves – and those of our customers.

4 To ensure optimum operation in the coldest climates the DEF (Ad Blue) system is fully prepared for harsh winter temperatures, heated supply lines and in tank heating ensures optimum performance in the coldest of climates.



EASY SERVICING AND MAINTENANCE.

WHEN IT COMES TO ROUTINE SERVICING AND MAINTENANCE YOU'LL EVEN NOTICE THE DIFFERENCE HERE. QUICK AND EASY ACCESS MEANS REDUCED DOWNTIME FOR THE NEW FASTRAC 4000 SERIES.

Designed with care.

1 Quick and easy access encourages regular service attention for a long and reliable working life – so the high-lift bonnet and fold-out cooling system make it easy to give your Fastrac the attention it deserves.

2 Dip the oil without lifting the bonnet, top up fuel, DEF (AdBlue) and oil for the hydraulics with ease as the fillers are all on the same side.

3 Reaching the batteries, battery isolator and brake fluid reservoirs could not be easier – just open a panel behind the right-hand cab steps.

4 External disc brake assemblies provide exceptional service access reducing service and maintenance downtime.



STATIC DIMENSIONS 4160, 4190, 4220

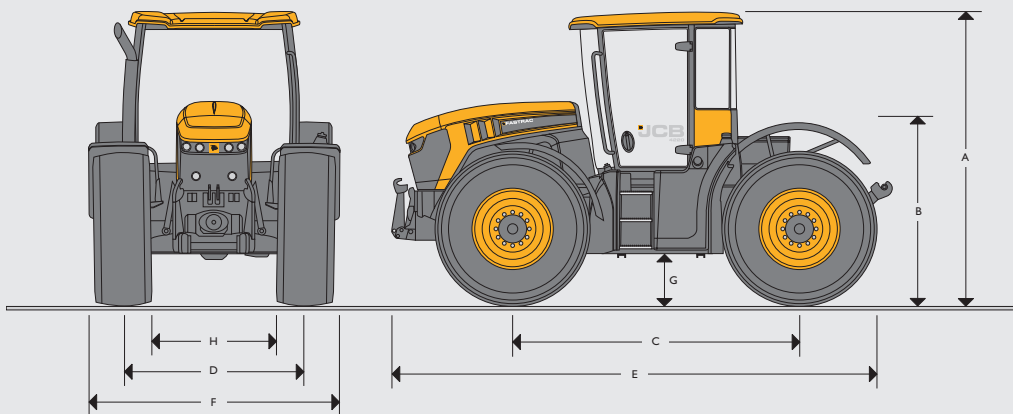

Tyres		540/65 R34	
A	Height over cab	m	3.00
B	Height to deck	m	1.67
C	Wheelbase	m	2.98
D	Track width	m	1.83 / 2.02 standard 1.93 / 1.78 reversed
E	Overall length	m	5.40
F	Overall width	m	2.55
G	Ground clearance	m	0.45
H	Width between tyres	m	1.47

ENGINE

Model		4220	
Rated power 97/68 EC	hp (kW)	217 (162)	
Max. power 97/68 EC	hp (kW)	235 (175)	
Max. torque @ 1450 rpm	Nm	950	
Make	AGCO Power		
Model	66AWF		
Injection	Bosch CP4 common rail		
No. of cylinders	6		
Capacity	ltr	6.6	
Bore	mm	108	
Stroke	mm	120	
Cooling	Water		
Air cleaner	Powercore dry element		
Aspiration	Turbocharged and intercooled		

SUSPENSION

Front and rear: Hydro-pneumatic self levelling. 45mm single-acting standard. 55mm double-acting option.

ELECTRICAL SYSTEM

System voltage	Volt	12
Alternator output	Amp	200
Battery capacity	Amp hour	2 x 110

CAPACITIES

Fuel tank	litres	390
Hydraulic tank	litres	130
Urea tank	litres	45

HYDRAULICS

Rear 3 point linkage control	Electronic raise/lower with depth, draft/position intermix, rate of drop and maximum lift height control plus external lift and lower.
Rear 3 point linkage type	Category III; Quick attach hook ends, eye end top link.
Rear 3 point linkage capacity	6000kgs, 7000kgs or 8000 kgs options available.
Front 3 point linkage (optional) control	Electronic raise/lower with depth, rate of drop and maximum lift height control plus external lift and lower.
Front 3 point linkage (optional) type	Category II; Quick attach hook ends, folding arm.
Front 3 point linkage (optional) capacity	3500kg

AUXILIARY HYDRAULICS

Max. oil flow @ 2100rpm rated speed	l/min	148
Flow per slice	l/min	100
Operating pressure	bar	210
Spool valves	Up to 6 double acting valves with flow and time control, constant pumping and float position.	
Standard (Agricultural version)	3 rear spools with rear free flow return,	
Optional (Agricultural version)	3, 4 or 5 rear spools, 0, 1 or 2 front spools, Front free flow return, Load sensing hydraulic connection (power beyond), Priority flow control (green spool).	
Standard (Utility version)	2 front and 3 rear spools with rear free flow return.	
Optional (Utility version)	2 or 3 rear spool valves. 2, 3 or 4 front spool valves, Front free flow return, Load sensing hydraulic connection (power beyond), Priority flow control (green spool).	
Couplers	Deluxe quick release (release under pressure type).	

POWER TAKE OFF

Rear PTO type	4 speed PTO with electro-hydraulic soft engage and electro-hydraulic speed shift.	
Rear PTO speeds	540 / 1000 / 540E / 1000E.	
Rear PTO output spline	6 or 21 spline 1 3/8" diameter (standard), 6 or 20 spline 1 3/4" diameter (options).	
Front PTO type (optional)	1000 rpm with electro-hydraulic soft engage. Centre output or offset output (Utility).	
Front PTO speed	1000 rpm @ 1900 engine rpm.	
Front PTO output spline	6 spline 1 3/8" or 1 3/4" (Utility) diameter.	
Model	4220	
PTO power	hp (kW)	195 (145)

AXLES	
Type	Beam with outboard epicyclic reduction hubs.
Wheel mountings	10 stud front axle, 10 stud rear axle.
Four wheel drive engagement	Electrohydraulic.
Differentials	Rear: electro-hydraulic soft engage. Front: No-spin or Maxtrac (automatic engagement).

STEERING	
Type	Standard: Hydrostatic steering, fixed ratio. Optional: Hydrostatic steering, GPS ready with RapidSteer.
Four wheel steer system	Advanced speed sensitive 4WS with multiple operation modes and auto controls.
Minimum 4WS turning circle	9.8m (540/65 R30).

BRAKES	
Type	4160: Outboard disc brakes, single caliper standard, twin caliper option. 4190/4220: Outboard disc brakes, twin caliper standard.
Operation	Air over hydraulic to EEC truck specification. ABS available in all territories as either standard fitment or option. Hillhold function optional on ABS tractors comes with traction control.
Trailer brakes	Standard twin line air trailer brakes. Territory specific single line hydraulic or single line air trailer brakes. Air trailer brake automatically applied by tractor park brake. ABS option includes 12V trailer ABS supply socket as standard.

TRANSMISSION	
Type	2 range continuously variable transmission with 6 modes of operation.
Speeds	Low range: 0-30kph. High range 0-60kph

VEHICLE WEIGHTS				
		Front axle	Rear axle	Total
Base machine	kg	3845	3730	7575
+ 600/70 R30, front link and front PTO	kg	4440	3900	8340
Maximum permissible vehicle weight	kg	Single caliper brakes: 9 tonnes. Twin caliper brakes: 13/14 tonnes (tyre dependent).		

WHEELS AND TYRES			
	Size	Track width standard mm	Track width reversed mm
Agricultural pattern	380/85 R38	8 Settings: 1530 to 2265	–
Agricultural pattern	540/65 R30	1930 / 2015	1830 / 1780
Agricultural pattern	540/65 R34	1830 / 2015	1930 / 1780
Agricultural pattern	540/65R34 Front & 600/70R30 Rear	2015	–
Agricultural pattern	600/70 R30	1830	1930
Agricultural pattern	710/60 R30	2000	–
Utility pattern	500/70 R24	1785	2015
Utility pattern	440/80 R30	1830	1930
Utility pattern	540/65 R30	1830	1930

Front directional and rear fixed fenders. All tyres are speed rated for 65kph.

CAB	Standard equipment includes:
	Fully automatic climate control, Air suspension seat with armrest mounted transmission and auxiliary controls, Colour touch screen display, providing transmission information and setup capability, Electronic spool valves, Category 2 filtration, Front and rear wash wipe, Front sunblind, Full road lighting equipment, Auxiliary electrical and speed sensor sockets, Full size passenger seat, Lap belt for driver and passenger, Side console illumination, Slimline backlit dashboard, Storage compartment, Radio preparation with single DIN slot and four speakers. Cable access through rear window, Rear fender mounted raise/lower and PTO switches.

OPTIONAL EQUIPMENT	Depending on model and territory:
	850kg front weight, 1000kg rear deck weight, 20 spline 1 1/4 PTO shaft, 6 spline 1 1/4 PTO shaft, Headland Turn Assist with radar and performance monitor, Deluxe seating options, Heated front and rear screens, Electric heated mirrors with additional wide angle lens, Auxiliary audio input, Halogen and LED worklights options, LED road lights, External rear fender control buttons, 7 pin front power socket, 3 pin front power socket, Interior rear view mirror, Automatic rear linkage stabilisers, Hookend/hydraulic top link, Electric cool box, Rear hitch camera, Roof window, Rear window blind, Rear deck sub-mounting frame, Rear deck 110mm ball hitch.

4000 SERIES INDUSTRIAL OPTIONS SUMMARY

- Utility front chassis with 200mm of height adjustable DIN mounting
- Offset front PTO
- Type B / 3, F1 -C / 5 (utility chassis mounted) and front linkage mounted DIN plates
- Front mounted 7 pin (lighting) and 3 pin (power supply) sockets
- Front axle Stability Control System
- Agricultural and utility rear deck frames
- 24" wheels
- Industrial/winter Nokian tyres
- Orange body panels

LIVELINK, WORK SMARTER.

JCB LIVELINK IS AN INNOVATIVE SOFTWARE SYSTEM THAT LETS YOU MONITOR AND MANAGE YOUR MACHINES REMOTELY – ONLINE, BY EMAIL OR BY MOBILE PHONE. LIVELINK GIVES YOU ACCESS TO A WHOLE HOST OF USEFUL DATA, INCLUDING MACHINE ALERTS, FUEL REPORTS AND EVENT HISTORY INFORMATION. ALL YOUR MACHINE INFORMATION IS HANDLED AT A SECURE DATA CENTRE FOR YOUR PEACE OF MIND.

Productivity and cost benefits

For ultimate productivity and cost-saving, JCB LiveLink provides information like idle time monitoring and machine fuel consumption to help reduce your fuel usage. Machine location information can improve fleet efficiency and you may even enjoy reduced insurance costs courtesy of the added security that LiveLink brings.

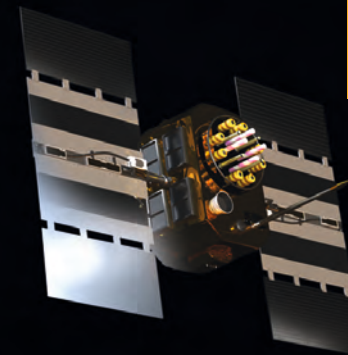

Maintenance benefits

JCB LiveLink makes it easy to manage machine maintenance. Accurate hours monitoring and service alerts improve maintenance planning, and real-time location data helps you manage your fleet. You'll also have access to critical machine alerts and maintenance history records.

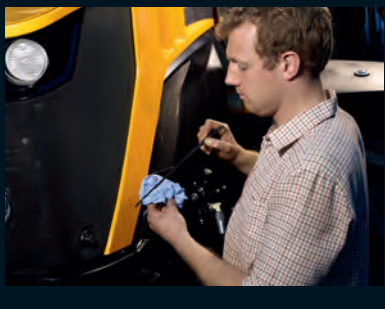

Security benefits

Keep your machine operating safely with JCB LiveLink. Real-time geofencing alerts tell you when machines move out of predetermined operating zones, and real-time curfew alerts inform you if machines are being used when they're not supposed to be. Real time location information helps you store your machines in the safest places.



Note: Please consult your local dealer for Livelink availability.

VALUE ADDED.

JCB'S WORLDWIDE CUSTOMER SUPPORT IS FIRST CLASS. WHATEVER YOU NEED AND WHEREVER YOU ARE, WE'LL BE AVAILABLE QUICKLY AND EFFICIENTLY TO HELP MAKE SURE YOUR MACHINERY IS PERFORMING TO ITS FULL POTENTIAL.



1

1 Our Technical Support Service provides instant access to factory expertise, day or night, while our Finance and Insurance teams are always on hand to provide fast, flexible, competitive quotes.

2 The global network of JCB Parts Centres is another model of efficiency; with 16 regional bases, we can deliver around 95% of all parts anywhere in the world within 24 hours. Our genuine JCB parts are designed to work in perfect harmony with your machine for optimum performance and productivity.

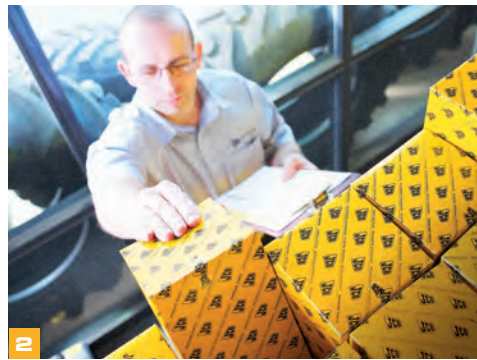

2

3 JCB Assetcare offers comprehensive extended warranties and service agreements, as well as service-only or repair and maintenance contracts. Irrespective of what you opt for, our maintenance teams around the world charge competitive labour rates, and offer non-obligation quotations as well as fast, efficient insurance repair work.



3

Note: JCB LIVELINK and JCB ASSETCARE may not be available in your region, so please check with your local dealer.

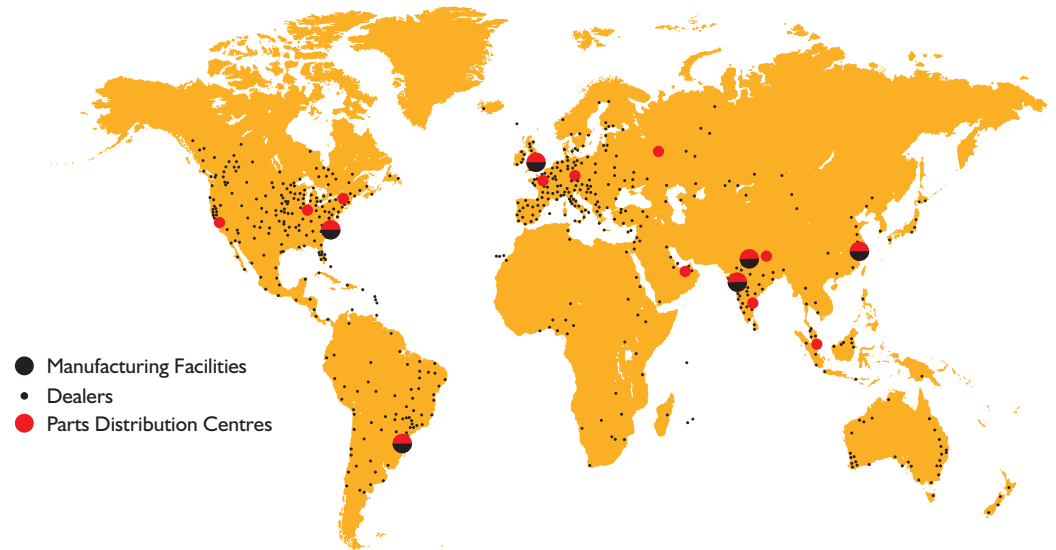



ONE COMPANY, OVER 300 MACHINES.

Your nearest JCB dealer

Fastrac 4000 Series

Rated power: 4220 217hp (162kW)

JCB Agriculture, Rokester, Staffordshire ST14 5JP.

Tel: +44 (0)1889 590312 Email: salesinfo@jcb.com

Download the very latest information on this product range at: www.jcb.com

[facebook.com/JCBAg](https://www.facebook.com/JCBAg)
[@JCBAgriculture](https://twitter.com/JCBAgriculture)
[youtube.com/JCBAgriculture](https://www.youtube.com/JCBAgriculture)

©2014 JCB Sales. All rights reserved. No part of this publication may be reproduced, stored in a retrieval system, or transmitted in any form or by any other means, electronic, mechanical, photocopying or otherwise, without prior permission from JCB Sales. All references in this publication to operating weights, sizes, capacities and other performance measurements are provided for guidance only and may vary dependant upon the exact specification of machine. They should not therefore be relied upon in relation to suitability for a particular application. Guidance and advice should always be sought from your JCB Dealer. JCB reserves the right to change specifications without notice. Illustrations and specifications shown may include optional equipment and accessories. All images are correct at time of print. The JCB logo is a registered trademark of J C Bamford Excavators Ltd.

9999/5850 en-GB 01/18 Issue 3

