

NEW



SKID STEER BACKHOE LOADER | ICX AND ICXT

Gross power: 36.3kW (49hp) Maximum dig depth: 3.05m Loader load over height: up to 2.65m



THE BEST OF BOTH WORLDS JUST GOT BETTER.

AT JCB, WE UNDERSTAND THE IMPORTANCE OF VERSATILITY AND THE DIFFERING DEMANDS OF SOME VERY DIVERSE SECTORS. THAT'S WHY WE'VE TAKEN THE WORLD'S SMALLEST BACKHOE LOADER TO NEW LEVELS. THE ICX HAS ALWAYS BEEN A VERSATILE COMPACT MACHINE, OFFERING SKID STEER AND EXCAVATOR PERFORMANCE IN ONE PACKAGE. NOW, WE GIVE YOU THE OPTION OF RUNNING ON TRACKS FOR REDUCED GROUND DAMAGE, SUPERLATIVE CLIMBING, EXCEPTIONAL PUSHING POWER, UNPARALLELED STABILITY AND IMPROVED SOFT GROUND PERFORMANCE.



A HISTORY OF INNOVATION.

THE ICX SKID STEER BACKHOE LOADER IS THE LATEST IN A LONG LINE OF JCB WORLD FIRSTS.

In fact, the entire concept of the backhoe loader itself was dreamt up by our company founder Joseph Cyril Bamford. We were also first to produce skid steer loaders with a single-side loader arm; there are numerous benefits to that unique layout, including side entry for greater safety.

In 1994, we introduced the JCB ICX which, for the first time, brought together the key features of a skid steer and a mini excavator. In 2012, we improved on our concept by adding Extradig, a handheld tool circuit, air conditioning, enhanced cab ergonomics and our Power Management System (PMS).

Today, the ICX boasts a choice of wheels or tracks for total productivity and versatility on any site. So the world's first remains very much the world's best.



As global market leader, JCB sells around half of all the world's backhoe loaders.



THE 50'S. The JCB MK1 Major Loader.

THE 60'S. The JCB 1.

1993. The JCB Skid Steer

1994. The JCB ICX.

2012. The new JCB ICX.

2014. The JCB ICXT.

A SOUND INVESTMENT.

THE NEW JCB ICX IS A COMPACT AND CLEVER MACHINE FROM THE WORLD'S NUMBER ONE BACKHOE LOADER MANUFACTURER. BY COMBINING KEY FEATURES OF A SKID STEER LOADER AND A MINI EXCAVATOR, YOU EFFECTIVELY GET TWO MACHINES IN ONE PACKAGE, SAVING TIME AND MONEY. A WEALTH OF SPECIAL FEATURES AND OPTIONS BOOST EARNING POWER STILL FURTHER.

More for your money.

1 On tracks or on wheels, the JCB ICX skid steer backhoe gives you the performance and versatility of two machines in one compact package. With the front end of a skid steer loader and the excavator arm of a mini at your disposal, you can now do two jobs without changing attachments.

2 The unique JCB Power Management System (PMS) provides control of the transmission setup, allowing you to increase machine pushing power whilst simultaneously reducing fuel consumption to save money.

3 If you want to operate high-flow attachments, choose the 100 l/min high-flow auxiliary circuit.

4 This machine combines tremendous durability with iconic JCB styling, high levels of build quality, and exemplary brand values; all of which leads to superior residual values.



A skid steer and more.

6 A ICX offers more dig depth and reach than a skid steer fitted with a backhoe attachment, not to mention greater loadover and dump height.

6 If you already have a skid steer, this machine's universal quickhitch will allow you to reuse existing attachments.

7 For ultimate excavation performance, opt for the tracked ICX-T; it has 14% more shovel capacity and better stability over rough terrain. The ICXT can work on a 31% gradient.

6 The ICX can turn through 360° on its own axis. Add that to its compact dimensions, and you have an ideal machine for cramped sites, basement areas and city centres.



QUALITY, RELIABILITY AND DURABILITY.

FUNDAMENTAL TO THE JCB ICX'S PRODUCTIVITY IS ITS BUILD QUALITY AND RELIABILITY. THROUGHOUT THE DESIGN AND MANUFACTURE PROCESS, WE'VE EMPLOYED NUMEROUS CUTTING-EDGE TECHNIQUES TO ENSURE HIGH LEVELS OF PERFORMANCE ARE MAINTAINED HOUR AFTER HOUR, DAY AFTER DAY.

Built to last.

1 Precision machining provides high tolerances and accurate location of pins and bushes. All steelwork on the JCB ICX is shot blasted and washed in a phosphate cleaner before being oven-baked to ensure longevity of the bodywork.

2 Our heavy-duty single-piece chassis provides a further boost to rigidity and service life. The chassis and componentry are extremely durable, which minimises downtime.

Tested to the limits.

3 All materials are tested to extreme temperatures and exposed to chemical, salt, oil and light to ensure maximum protection in even the most hostile conditions. Quality control processes like finite element analysis and rig testing help to achieve ultimate structural strength and durability. Cold cell testing guarantees starting performance down to -20°C.



Protected from damage.

- 4 All hydraulic hoses are intelligently routed to reduce wear and prevent damage, thereby increasing service life and reducing downtime.
- 5 The backhoe unit is integrated with the machine, which keeps dimensions compact. It folds away well within the machine's overall footprint, making transport and site travel easy and safe.
- 6 Raised front and rear lights reduce the risk of damage and improve visibility.



Built to perform.

- 7 The ICX excels in both uneven terrain and confined spaces thanks to a winning combination of high ground clearance and an excellent turning circle.
- 8 Track retention is excellent on the ICXT machine, courtesy of a solid undercarriage with four cast steel triple-flanged rollers (most competitor small platform machines only have 3).
- 9 The 320mm tracks give a footprint of 0.8m² giving advantages of low ground pressure, allowing the machine to be used on wet ground or where it is important for ground damage to be kept to a minimum.



PRODUCTIVITY AND PERFORMANCE.

WHATEVER THE JOB, YOU CAN BE SAFE IN THE KNOWLEDGE THAT A JCB ICX OFFERS SUPERIOR PRODUCTIVITY. WE'VE INSTALLED A POWERFUL TIER 3 ENGINE IN THIS COMPACT AGILE MACHINE, TOGETHER WITH THE LOADING AND DIGGING CAPABILITIES TO TACKLE THE TOUGHEST JOBS.

Power is provided by a 36.3kW (49hp) engine with 2800rpm – that's enough to operate a 5 tonne mini excavator. To improve stability, both the engine and transmission are mounted low in the chassis.

The front loader.

1 The front loader carries a standard skid steer hitch for similar lift capacity to any 600kg skid steer. However, the unique design of the ICX – tracked or wheeled – means you can expect a 25% greater dump angle and 15% more breakout.

Loadover height is a lofty 2.59m on the wheeled ICX and 2.65m on the tracked model, allowing for smooth loading into high-sided lorries.

2 Thanks to JCB's standard-fit four-ram geometry with parallel lift, your loader attachment will always stay level during raising and lowering (conventional skid steer loader arms only stay level during the upward part of the cycle).

3 A 45 l/min standard hydraulic flow rate is ample for a wide range of typical skid steer attachments. If you need ultimate performance – for operating hydraulically-driven attachments like augers, patch planers and trenchers for example – then opt for our 100 l/min high flow system.



The backhoe.

- 4 With a fully integrated sideshift backhoe, this machine can dig close to walls, making it ideal for street working.
- 5 Dig up to 3.05m by equipping your ICX with our extending dipper option which dramatically reduces the number of times you reposition when trenching and makes for easier loading.
- 6 Impressive power equivalent to a 2.5 tonne mini excavator is accompanied by optional extending dipper which results in a dig depth of 3.05m, 3.91m ground level reach and 2.65m loadover height, whilst reducing the amount of machine movement for increased productivity.
- 7 Our optional mechanical quickhitch is designed to meet stringent JCB standards; they make for quick and efficient attachment changes.



320mm (12.8") wide tracks reduce ground pressure and damage and give the ICX incredible traction in wet and tough conditions, enabling it to work where conventional skid steer machines would not be able to access.



COMFORT AND EASE OF USE.

FOR OPTIMUM PRODUCTIVITY AND SAFETY, IT'S ESSENTIAL THAT YOUR OPERATORS STAY FRESH AND ALERT. FOR THIS REASON, THE JCB ICX'S CAB IS COMFY, SPACIOUS, EASY TO ACCESS AND RELATIVELY QUIET. IT CAN ALSO ACCOMMODATE A RANGE OF ERGONOMIC CONTROL SYSTEMS.

Whether you opt for a cab or canopy on your ICX, you'll benefit from side entry so, unlike on a conventional skid steer, there's no need to climb over attachments to gain access.



A productive operator environment.

- 1 Choose the perfect cab solution for your business: a full cab with integrated heating and optional air-conditioning; a standard canopy option; or a low-height canopy for extra manoeuvrability.
- 2 The operator can face a $\frac{3}{4}$ position for lorry loading on Easy Control models.
- 3 A cab roof height of under 2.4m is ideal for easy access to basement dig areas. A low canopy option is also available.



Making life easier.

JCB's Power Management System (PMS) gives operators the option of regulating the power that runs through the drive motors; this makes for a robust and reliable anti-stall system. Quick and efficient attachment changes are made possible with our standard mechanical quickhitch. Both units meet stringent JCB quality standards. The ICX's high-flow hydraulics incorporate enhanced quick-release couplings for the safe and speedy connection of hydraulic pipework.

Effortless control.

4 You can specify your JCB ICX with one of two different control types – Manual or EasyControl (servo)*. With both systems operators can still achieve the very highest levels of precision and productivity with low-effort EasyControl. For ultimate customisation, choose switchable SAE+ and ISO+ control patterns (EasyControl only).

5 Manual control is familiar to seasoned backhoe operators. Driving and front loading are carried out via seat-mounted servo joysticks, while the backhoe is operated by rear-facing manual levers.

6 EasyControl replicates the controls of a mini excavator. Drive, front loader and excavator commands are all found on the same seat-mounted servo joysticks; changing the joysticks to excavation mode is a simple case of rotating the seat and flicking a switch.

*EasyControl is more ergonomic.

Control options summary		
	Manual Control	EasyControl
Typical operator	Traditional backhoe operator	Traditional backhoe operator wanting better ergonomics
		Operators who are unfamiliar with backhoe controls
Excavator controls	Manual	Servo
Loader controls	Servo	Servo
Control patterns	JCB X Diagonal ISO + SAE +	ISO + SAE + Optional switch between both
Pump type	Gear pump	Gear pump
Extradig operation	Rocker pedal by right foot	Proportional switch on right joystick
Auxiliary operation (e.g. hammer)	Rocker pedal by right foot	Proportional switch on right joystick
6-in-1 operation	Switch on right joystick	Proportional switch on right joystick

JCB X (Diagonal) Manual Only



ISO+ Manual & EasyControl

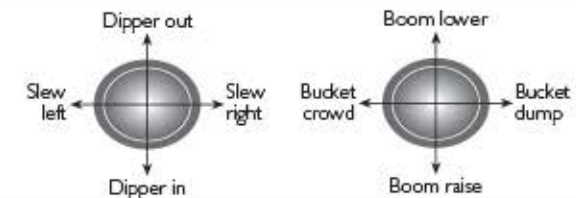

SAE+ Manual & EasyControl

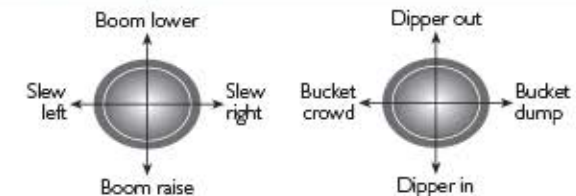

SERVICEABILITY AND SAFETY.

MINIMISING DOWNTIME IS AN ESSENTIAL PART OF MAXIMISING PROFIT, SO THE LATEST JCB ICX IS BOTH EASY TO SERVICE AND SAFE TO OPERATE. THE MACHINE IS PACKED WITH FEATURES TO LENGTHEN SERVICE INTERVALS OR PROVIDE PROTECTION FOR MACHINERY, OPERATORS AND BYSTANDERS.

Lengthy 500-hour engine service intervals mean the ICX enjoys less downtime compared with many rival machines.



Servicing made easy.

1 With a wide one-piece bonnet and removable side panels, the ICX affords quick, easy ground level access to daily checks and routine service items.

2 A large side-mounted 40-litre fuel tank allows both long working stints and easy refuelling. Its long filler neck reduces spillage and there's also a lockable cap as standard. The tank is made of plastic, which prevents rusting and protects the fuel system, while the highly visible external fuel gauge can be seen easily from the operator's seat.

3 Hydraulic oil level is clearly shown via a rear mounted site gauge. Access to internal strainer is from ground level. JCB's Optimum Performance hydraulic oil increases the service life and performance of your machine.



Stay safe.

- 4 Getting in and out of a JCB ICX is easy and safe courtesy of large anti-slip steps. Not only that, but there are three points of contact available to an operator when entering and exiting the machine.
- 5 The ICX's cab glass not only permits superb all-round visibility, but it ensures operator safety too. A large laminated front screen and toughened glass everywhere else gives good protection during powered attachment use and, in the event of a breakage, the panes are easy to replace.
- 6 The rear boom can be manually locked for added safety when roading.
- 7 Ignition, working lights, park brake and control switches are all quickly located on the right-hand control panel, along with the hour meter and warning light cluster, which includes an audible malfunction warning buzzer. The machine's wiring is rated to IP69.
- 8 There's a reversing alarm and flashing beacon; you can also add a fire extinguisher, front screen guard and external mirrors for increased safety and security.



THE OPTIONS LIST.

IN ITS STANDARD TRIM, THE NEW JCB ICX IS A HIGHLY PRODUCTIVE, VERSATILE MACHINE. BY TAILORING IT TO YOUR EXACT NEEDS WITH OUR EXTENSIVE SELECTION OF OPTIONAL EXTRAS, YOU CAN EXPECT EVEN GREATER LEVELS OF PERFORMANCE ACROSS A HUGE RANGE OF DIFFERENT DISCIPLINES.



Dozing



Loading



Grabbing



Grading



Digging



Backfilling

6-in-1 shovel.

1 This highly versatile optional tool can dig, doze, load, grab, grade or backfill.

Excavator quickhitch.

2 Fitting an optional quickhitch to the backhoe allows faster attachment changes.

High-flow hydraulics.

3 The optional 100 l/min hydraulics package is ideal for utilities applications because it can power high-flow attachments like patch planers and trenchers.

Increase your ICX's versatility by opening up a wide range of universal skid steer attachments.



Extending dipper.

4 By dramatically increasing the dipper's dig depth, reach and loadover height, you get large excavator performance in a compact package.



Hammer/bi-directional circuit.

5 To enhance your I CX's versatility and earning potential, this feature allows you to operate a range of single and double-acting tools (like hammers or earth drills) from the same circuit.



Stabiliser street pads.

6 Eliminate any possible damage by stabiliser feet to tarmac or paved surfaces with the street pads option – ideal for utilities work.



Handheld tool circuit.

7 Easy to access quick couplers allow fast connection. You can use your backhoe loader as a power source for a wide range of handheld tools including breakers, water pumps or disc cutters. This solution increases versatility whilst reducing noise and vibration. This handheld tool circuit is unique to JCB; it meets EHTMA Class C tool operation standards, and can operate tools like breakers, water pumps, trash pumps and disc cutters.

Air conditioning.

8 The optional air conditioning system has a three-speed blower and heater facility, as well as front and rear window demisting vents.



LIVELINK, WORK SMARTER.

JCB LIVELINK IS AN INNOVATIVE SOFTWARE SYSTEM THAT LETS YOU MONITOR AND MANAGE YOUR MACHINES REMOTELY – ONLINE, BY EMAIL OR BY MOBILE PHONE.

Productivity and cost benefits

Machine location information can improve fleet efficiency and you may even enjoy reduced insurance costs courtesy of the added security that LiveLink brings.

* Note: Please consult your local dealer for LiveLink availability



Maintenance benefits

Accurate hours monitoring, maintenance history records, critical machine alerts and service alerts improve maintenance planning.



Security benefits

Real-time geofencing lets you set operating zones and curfew alerts that tell you when your machinery outside of pre-determined times. Location information helps you store machines safely.



Note: Please consult your local dealer for LiveLink availability.



VALUE ADDED.

JCB'S WORLDWIDE CUSTOMER SUPPORT IS FIRST CLASS. WHATEVER YOU NEED AND WHEREVER YOU ARE, WE'LL BE AVAILABLE QUICKLY AND EFFICIENTLY TO HELP MAKE SURE YOUR MACHINERY IS PERFORMING TO ITS FULL POTENTIAL.



1 Our Technical Support Service provides instant access to factory expertise, day or night, while our Finance and Insurance teams are always on hand to provide fast, flexible, competitive quotes.

2 The global network of JCB Parts Centres is another model of efficiency; with 16 regional bases, we can deliver around 95% of all parts anywhere in the world within 24 hours. Our genuine JCB parts are designed to work in perfect harmony with your machine for optimum performance and productivity.



3 JCB Assetcare offers comprehensive extended warranties and service agreements, as well as service-only or repair and maintenance contracts. Irrespective of what you opt for, our maintenance teams around the world charge competitive labour rates, and offer non-obligation quotations as well as fast, efficient insurance repair work.



STATIC DIMENSIONS

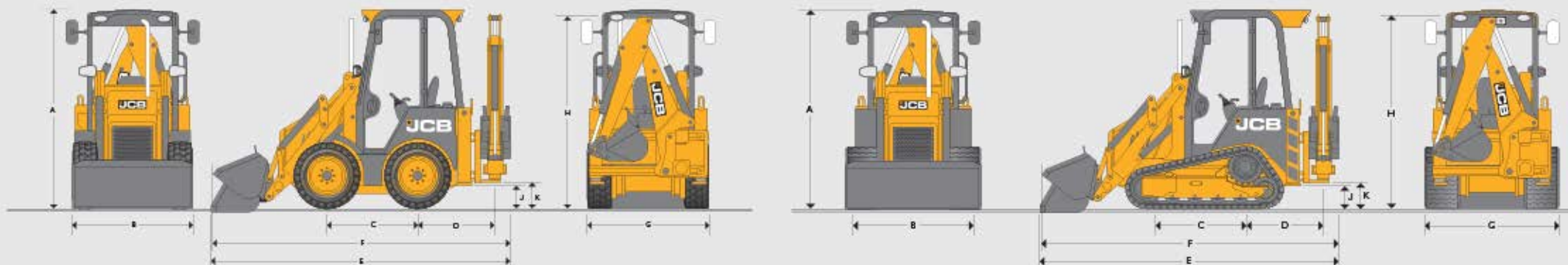

		ICX Wheeled (10x16.5 Tyres)	ICX Tracked (320mm)	
A	Cab roof height	m	2.25	2.38
A	Cab roof height (low canopy)	m	2.10	2.23
B	Overall width (over shovel)	m	1.58	1.80
C	Axle centreline distance	m	1.07	-
D	Slew centre to rear axle centre distance	m	0.87	-
E	Total travel length (short/long arm)	m	3.40 / 3.50	3.57
F	Total travel length – shovel in carry position (short/long arm)	m	3.31 / 3.41	3.47
G	Rear frame width (over stab leg feet)	m	1.56	1.80
H	Total travel clearance (fixed dipper)	m	2.17	2.20
	Total travel clearance (extending dipper)	m	2.17	2.27
J	Stabiliser feet clearance	m	0.26	0.26
K	Kingpost clearance	m	0.32	0.32
	Track set footprint	m ²	-	0.85

GROUND LINE ANGLES

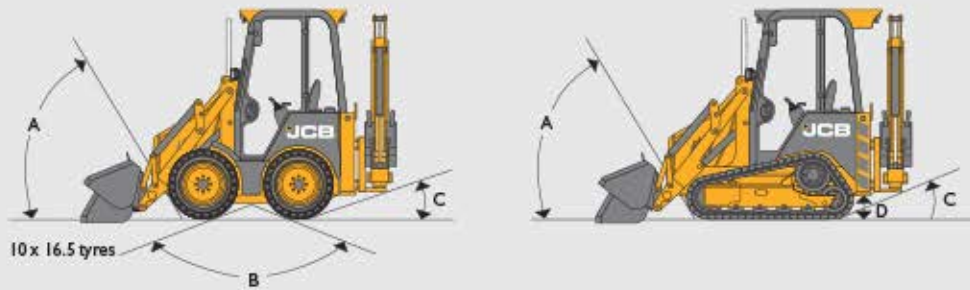

		ICX Wheeled	ICX Tracked	
A	Approach angle	degrees	52	60
B	Interface angle/ramp to ground plane	degrees	132	-
C	Departure angle	degrees	23	23
D	Ground clearance	mm	180	260

ENGINE

	ICX – All models	
Emissions standard	Stage EC Stage IIIA	
Manufacturer	Perkins 404D-22	
Aspiration	Natural	
Displacement	litres	2.2
No. of cylinders	4	
Rated engine	rpm	2800
Power ratings		
Rated ISO 14396 (SAE J1995 Gross)	kW (hp)	36.3 (49)
Max. torque @ 1800rpm	Nm	140
Fuel type	Diesel	
Fuel filter	Replaceable cartridge plus water/sediment separator prefilter	
Air cleaner	Dual element	
Oil filter and lubrication	Full flow, spin-on type filter. Engine oil service intervals 500 hours	
Cooling system	Water, hot climate specification. Pressurised 1.0 bar, pusher fan. Pressurised tank with integral filler neck and overflow tank.	

ELECTRICAL AND INSTRUMENTATION

Gauges	Fuel Level, Hour meter
Warning system	Audible and visual system. Ignition, working lights, park brake, alternator, main beam, engine oil pressure, water temp.
Battery	72A/hour
Pre-wire	Beacon
Horn	Controlled from both front and rear
Alternator	50 amp standard (85A alternator on the aircon option)
Front working lights	2 adjustable
Rear working lights	2 adjustable

TRANSMISSION

	ICX - All models
Manufacturer	Danfoss / Rexroth
Type	Hydrostatic
Travel speeds	ICX 0-11 km/h forward & reverse ICXT 0-7.5 km/h forward & reverse

OPERATING WEIGHTS

		ICX Wheeled		ICX Tracked
		Short Arms	Long Arms	Long Arms
Fixed dipper	kg	3158	3174	4262
Extended dipper	kg	3238	3254	4342

SERVICE CAPACITIES

	ICX – All models	
Hydraulic system including tank	ltr	45
Fuel tank	ltr	45
Chain cases	ltr	10
Cooling system	ltr	8
Engine oil with filter	ltr	9.6

HYDRAULIC SYSTEM

		ICX Wheeled	ICX Wheeled HF	ICX Tracked	ICX Tracked HF
Open centre systems (gear pump) @2800 rpm services	l/min	45	45	45	45
Open centre systems (gear pump) @2800 rpm HF	l/min	-	100	-	100
System relief pressure Manual	bar	207	207	207	207
System relief pressure EasyControl	bar	220	220	220	220
Handheld tool circuit	l/min	20	20	20	20
Handheld tool circuit	bar	138	138	138	138

LOADER DIMENSIONS

		ICX Wheeled		ICX Tracked	
		Short Arms	Long Arms	Long Arms	
M	Dump height	m	2.10	2.15	2.21
N	Load over height	m	2.51	2.59	2.65
O	Loader hinge pin height	m	2.70	2.80	2.86
P	Reach at ground (toe plate horizontal)	m	0.84	0.91	1.41
Q	Maximum reach at full height	m	0.63	0.74	0.74
R	Reach at full height fully dumped	m	0.30	0.40	0.40
S	Dig depth (toe plate horizontal) clearance	m	0.05	0.14	0.05
T	Roll back at ground	degrees	35	42	42
U	SAE Dump angle	degrees	43	43	43
	SAE Loader breakout – shovel	kgf	2350	2350	2350
	SAE Maximum hydraulic lift capacity	kgf	1050	1000	1000
	Shovel capacity	m ³	0.28	0.28	0.36

LOADER PERFORMANCE

		ICX Wheeled	ICX Tracked
		6-in-1 shovel	6-in-1 shovel
Loader breakout – shovel		2350	2350
Loader breakout – arms		2400	2400
Tipping load	kg	1160 - 1320	1900
Payload rating as a percentage of tipping load	%	50	35
Rated operating capacity	kg	Range from 580 to 660	665

*Rated operating capacity as determined according to ISO 14397: 2007

Depending on specification

Track mc includes extending dipper

BACKHOE DIMENSIONS

		ICX Wheeled		ICX Tracked		
		Fixed Dipper	Extended Dipper	Fixed Dipper	Extended Dipper	
A	SAE Maximum dig depth	m	2.55	3.08	2.55	3.08
	SAE Maximum dig depth 2ft flat bottom	m	2.49	3.02	2.49	3.02
B	Reach – ground level to rear wheel centre	m	4.24	4.78		
C	Reach – ground level to slew centre	m	3.38	3.91	3.38	3.91
D	Reach – at full height to slew centre	m	1.79	2.22	1.79	2.22
E	Side reach – to centre line of machine	m	3.83	4.35	3.83	4.35
F	SAE operating height	m	3.44	3.86	3.44	3.86
G	Maximum loadover height	m	2.35	2.67	2.35	2.67
H	Total kingpost travel	m	0.99	0.99	1.19	1.19
J	Bucket rotation	degrees	202	180	202	180
	Bucket tearout	kgf	2201	2201	2201	2201
	Dipper tearout	kgf	1488	1488	1488	1488

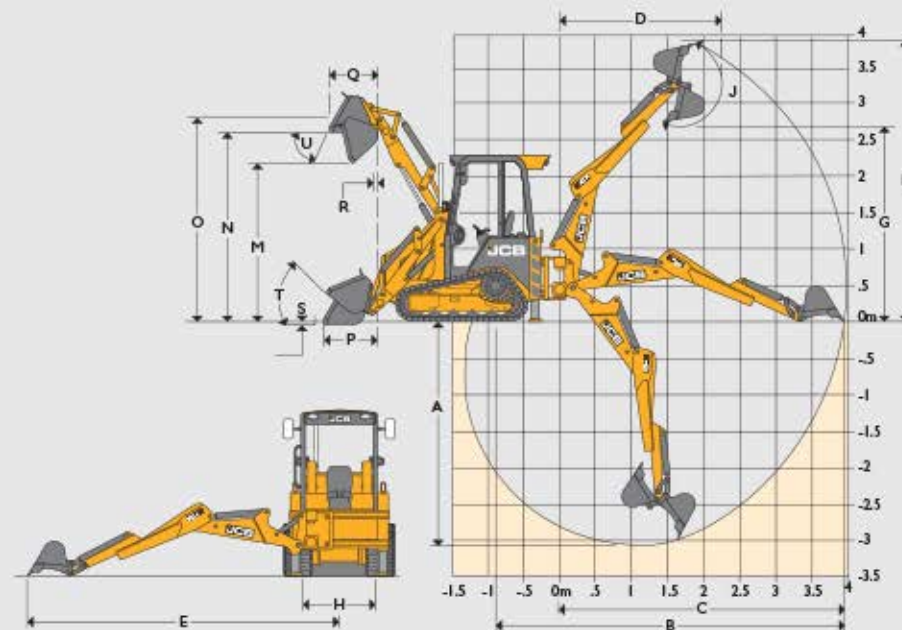
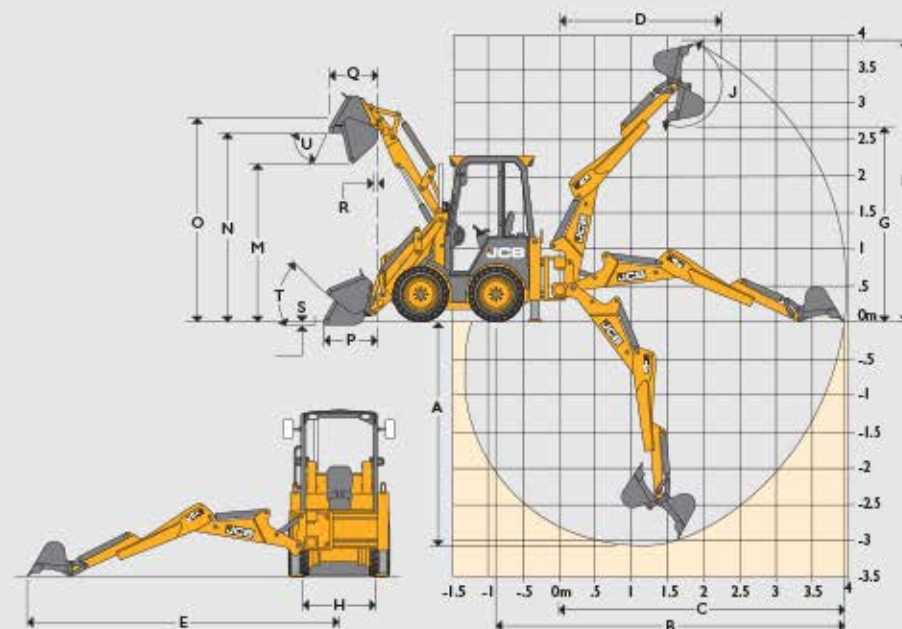

LOADER ATTACHMENTS – FORKLIFT PERFORMANCE DATA

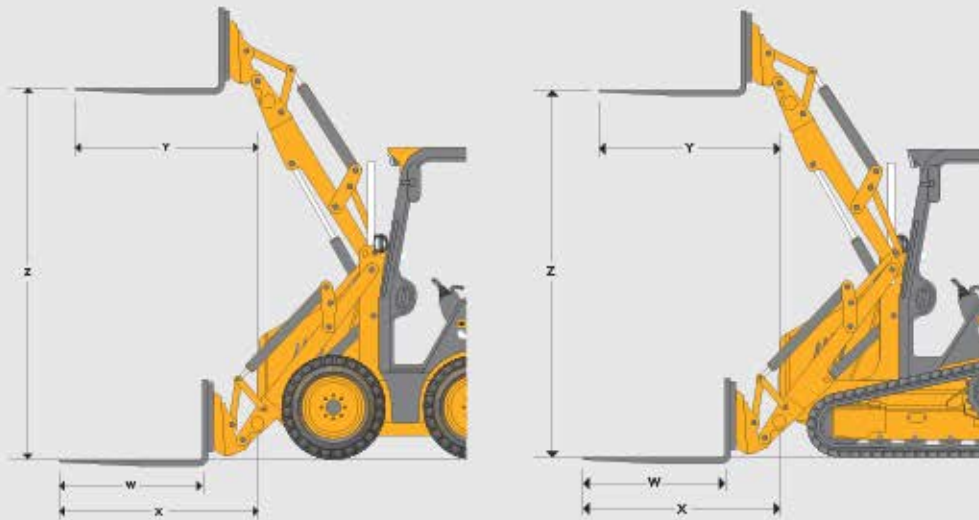

	ICX Wheeled		ICX Tracked
	Short arms	Long Arms	Long Arms
Quickhitch mounted forks			
W Forks – tine length	m	1.05	1.05
Forks – tine width	m	0.08	0.08
X Forks reach at ground level	m	1.50	1.6
Y Forks reach at full height	m	1.34	1.40
Z Forks lift height – max.	m	2.67	2.82
Fork spacing – min.	m	0.2	0.2
Fork spacing – max.	m	1.03	1.03
Tipping Load @ 500mm load centres fixed dipper		932	880
SWL @ 500mm load centres fixed dipper	kg	466	440
Tipping Load @ 500mm load centres extending dipper		1026	908
SWL @ 500mm load centres extending dipper	kg	513	454
SWL @ 500mm load centres extending dipper	kg	513	454
Payload rating as a percentage of tipping load ISO 14397-1	%	50	50
			35

OPTIONAL ACCESSORIES	
Machine model	ICX - All models
Tyres	Tyres size 10 x 16.5 NHS 6PR. Grassland tyres for minimised ground disturbance.
Tracks	320 x 86 x 4300
Controls	ISO+ pattern excavator controls, SAE+ pattern excavator controls, JCB X-pattern excavator controls (Manual control mcs only), EasyControl in Servo SAE/ISO or Switchable SAE/ISO
Machine features	Fully glazed ROPS/FOPS cab, road lights, face level fan, external mirrors, fire extinguisher, air filter pre-cleaner.
Machine and site protection	Flashing beacon, reverse alarm, large stabiliser feet, stabiliser street pads, front screen guard.
Attachments	Front loader auxiliary circuit, front shovel float, auxiliary hand held tool circuit, excavator bucket quickhitch, hammer/bi-directional auxiliary circuit, pallet forks and frame.

NOISE & VIBRATION LEVELS	
	ICX – All models
Internal	dB(A) 82
External	dB(A) 101
Vibration	Hand arm vibration does not exceed 2.5m/s ² for all duties with the exception of rough road tracking which averages 3.4m/s ² Whole body vibration 0.29m/s ²

LOADER ATTACHMENTS – DIRECT MOUNT				
	ICX Wheeled		ICX Tracked	
	GP shovel	6-in-1 shovel	GP shovel	6-in-1 shovel
	Capacity SAE	Capacity SAE	Capacity SAE	Capacity SAE
Width mm	Rated m ³	Rated m ³	Rated m ³	Rated m ³
1580	0.32	0.31	N/A	N/A
1800	N/A	N/A	0.37	0.36

BACKHOE ATTACHMENTS – STANDARD PROFILE BUCKET				
	ICX – All models			
	Capacity SAE		Weight (+ Teeth)	
Width (Including sidecutters. Width less sidecutters deduct 25mm)	Rated m ³	Struck m ³	kg	Teeth
mm				
230	0.03	0.02	51	2
305	0.04	0.04	52	3
460	0.06	0.05	54	3
610	0.08	0.06	57	4

DITCHING BUCKETS			
	ICX – All models		
	Capacity SAE		Weight
	Rated m ³	Struck m ³	kg
Width 1000mm	0.12	0.10	52





